



FUJI ELECTRIC

SPLIT TYPE AIR CONDITIONER

CASSETTE type (50Hz)

SERVICE MANUAL

Models	Indoor unit	Outdoor unit
	RCW-18	ROCW-18
	RCW-25	ROCW-25
	RCW-36	ROCW-367
	RCW-45	ROCW-457

C O N T E N T S

SPECIFICATIONS	1
DIMENSIONS	3
CIRCUIT DIAGRAM	5
REFRIGERANT SYSTEM DIAGRAM	10
DISASSEMBLY ILLUSTRATION	12
PARTS LIST	22



Большая библиотека технической документации

<https://splitsystema48.ru/instrukcii-po-ekspluatacii-kondicionerov.html>

каталоги, инструкции, сервисные мануалы, схемы.

S P E C I F I C A T I O N S

MODEL			RCW-18	RCW-25	RCW-36	RCW-45	
			ROCW-18	ROCW-25	ROCW-367	ROCW-457	
COOLING CAPACITY	kW		5.25 - 5.40	7.00 - 7.10	10.3 - 10.5	12.4 - 12.7	
POWER SUPPLY			1 ~ 220-240V 50Hz		3N ~ 380-415V 50Hz		
TOTAL INPUT	kW		2.05 - 2.15	2.64 - 2.77	3.73 - 3.80	4.45 - 4.57	
TOTAL CURRENT	A		9.40 - 9.20	12.8 - 13.2	6.4 - 6.4	7.5 - 7.5	
E E R	kW/kW		2.56 - 2.51	2.65 - 2.56	2.76 - 2.76	2.79 - 2.78	
STARTING CURRENT	A		50	61	42	55	
INDOOR UNIT	FAN SPEED	HI	r. p. m.	500	580	570	680
		MED	r. p. m.	430	510	470	570
		LOW	r. p. m.	360	430	380	490
	AIR CIRCULATION	HI	m ³ /h	1,000	1,200	1,400	1,700
		MED	m ³ /h	850	1,025	1,150	1,500
		LOW	m ³ /h	700	850	900	1,200
	NOISE LEVEL (SOUND PRESSURE)	HI	dB	41.5	45.0	49.0	53.5
		MED	dB	37.0	42.0	45.0	50.0
		LOW	dB	34.0	39.0	42.5	46.5
	HEAT EXCHANGER			Plate fin coil			
	FAN TYPE x Q' TY			Turbo fan x 1			
	FAN MOTOR OUTPUT		kW	0.037		0.042	0.088
	OPERATION CONTROL			L. C. D wireless remote controller			
	DIMENSIONS	H	mm(inch)	216 (8-1/2")		302 (11-7/8")	
W		mm(inch)	800 (31-1/2")		800 (31-1/2")		
D		mm(inch)	800 (31-1/2")		800 (31-1/2")		
WEIGHT	kg		26		38		
GRILLE	DIMENSIONS	H	mm(inch)	80 (3-5/32")		80 (3-5/32")	
		W	mm(inch)	950 (37-13/32")		950 (37-13/32")	
		D	mm(inch)	950 (37-13/32")		950 (37-13/32")	
	WEIGHT	kg		6.5		6.5	
OUT-DOOR UNIT	FAN SPEED	HI	r. p. m.	740		790	
		LO	r. p. m.	280		—	
	AIR CIRCULATION	HI	m ³ /h	2,590		5,900	5,500
	NOISE LEVEL		dB	56.0		57.5	59.0
	HEAT EXCHANGER			Plate fin coil			
	FAN TYPE x Q' TY			Propeller fan x 1		Propeller fan x 2	
	FAN MOTOR OUTPUT		kW	0.060		0.063 x 2	
	COMPRESSOR	TYPE		AWG5524EXC	AWG5532EXC	CRLQ-0350-TFD	CRPQ-0450-TFD
		PROTECTION		Internal protector (OCR), High pressure relief valve			
	COMPRESSOR MOTOR OUTPUT		kW	1.5	2.0	3.0	3.7
	DIMENSIONS	H	mm(inch)	643 (25-5/16")		1,152 (45-11/32")	
W		mm(inch)	840 (33-1/16")		940 (37")		
D		mm(inch)	336 (13-7/32")		370 (14-9/16")		
WEIGHT	kg		66	67	94	102	

MODEL			RCW-18	RCW-25	RCW-36	RCW-45	
			ROCW-18	ROCW-25	ROCW-367	ROCW-457	
REFRIGERANT CIRCUIT	DISCHARGE PRESSURE	kg/cm ² G	19.2	19.9	18.8	19.0	
	SUCT. PRESSURE	kg/cm ² G	4.9	4.9	5.1	5.0	
	DISCHARGE TEMP.	°C	93	90	90	90	
	REFRIG. PIPE LENGTH	m	5				
	DISCHARGE AIR TEMP.	°C	14	14	11	12	
CONDITION	INDOOR ENTERING AIR TEMP.	DB/WB °C	27.0/19.0				
	OUTDOOR ENTERING AIR TEMP.	DB/WB °C	35.0/24.0				
PIPING	PIPE DIA.	LIQUID mm(inch)	9.53(3/8")				
	SIZE	GAS mm(inch)	15.88(5/8")		19.05(3/4")		
	CONNECTION METHOD		Flare				
	BETWEEN	HEIGHT	m	Max. 15		Max. 30	
		PIPE LENGTH	m	Max. 25		Max. 50	

ADDITIONAL REFRIGERANT CHARGE

Pipe length		5 m (16 ft.)	10 m (33 ft.)	15 m (49 ft.)	20 m (66 ft.)	25 m (82 ft.)	30 m (99 ft.)	40 m (132 ft.)	50 m (165 ft.)	Additional refrigerant g/m (oz./ft)
FULL CHARGE AMOUNT	RCW-18	1,140 g (40.2 oz.)	1,200 g (42.4 oz.)	1,260 g (44.5 oz.)	1,320 g (46.6 oz.)	1,380 g (48.7 oz.)	/	/	/	12 (0.42)
	RCW-25	1,950 g (68.8 oz.)	2,010 g (70.9 oz.)	2,070 g (73.0 oz.)	2,130 g (75.1 oz.)	2,190 g (77.3 oz.)	/	/	/	12 (0.42)
	RCW-36	2,150 g (75.9 oz.)	2,285 g (80.6 oz.)	2,420 g (85.4 oz.)	2,555 g (90.1 oz.)	2,690 g (94.9 oz.)	2,825 g (99.7 oz.)	3,095 g (109.2 oz.)	3,365 g (118.7 oz.)	27 (0.95)
	RCW-45	3,150 g (111.1 oz.)					3,550 g (125.2 oz.)	3,950 g (139.3 oz.)	4,350 g (153.4 oz.)	40 (1.41)

DIMENSIONS

Models : RCW-18/ROCW-18
 RCW-25/ROCW-25

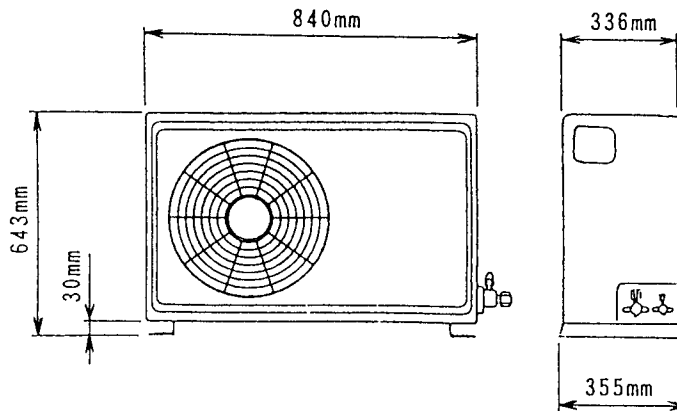
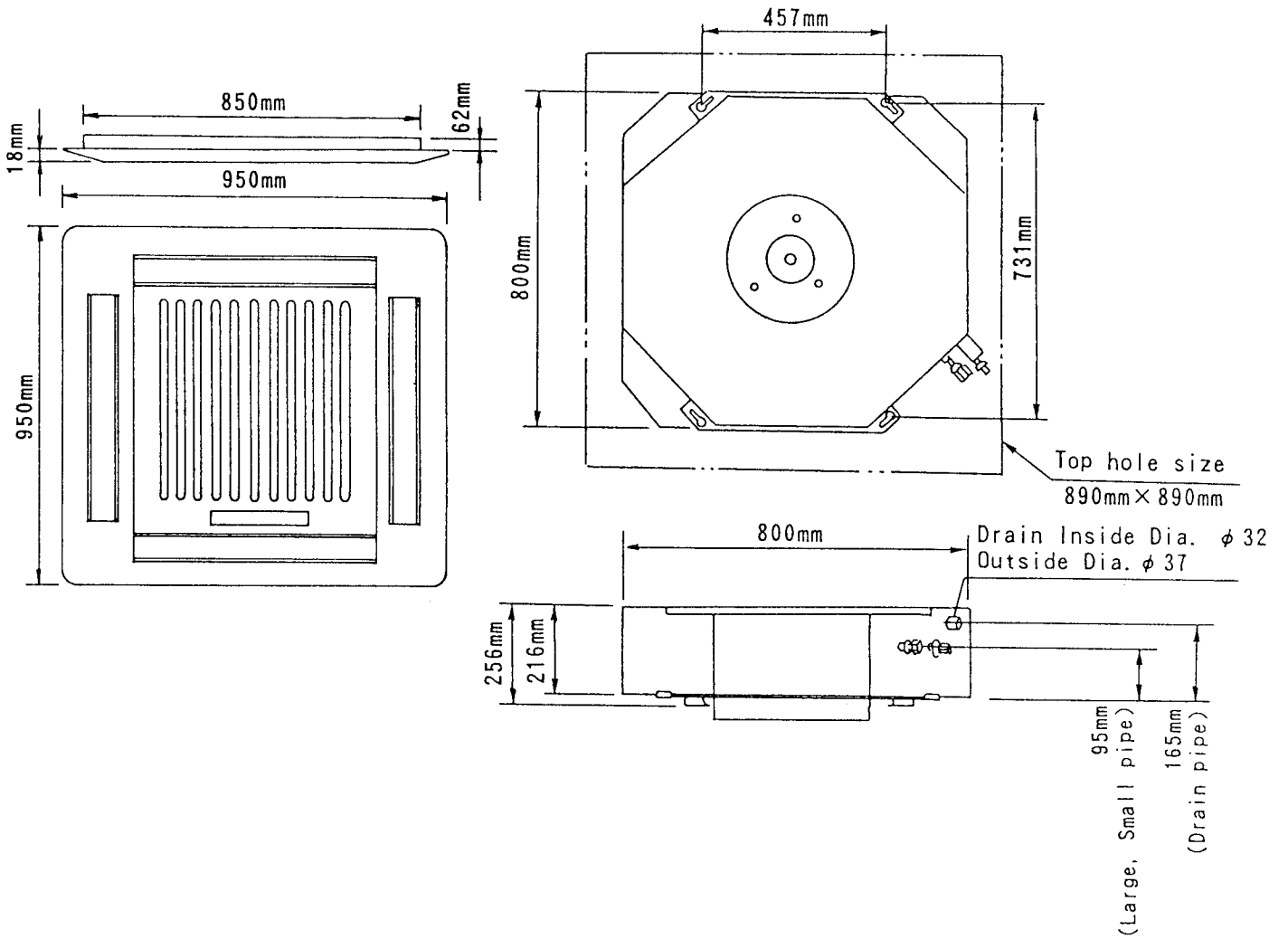

Models : RCW-36/ROCW-367
 RCW-45/ROCW-457

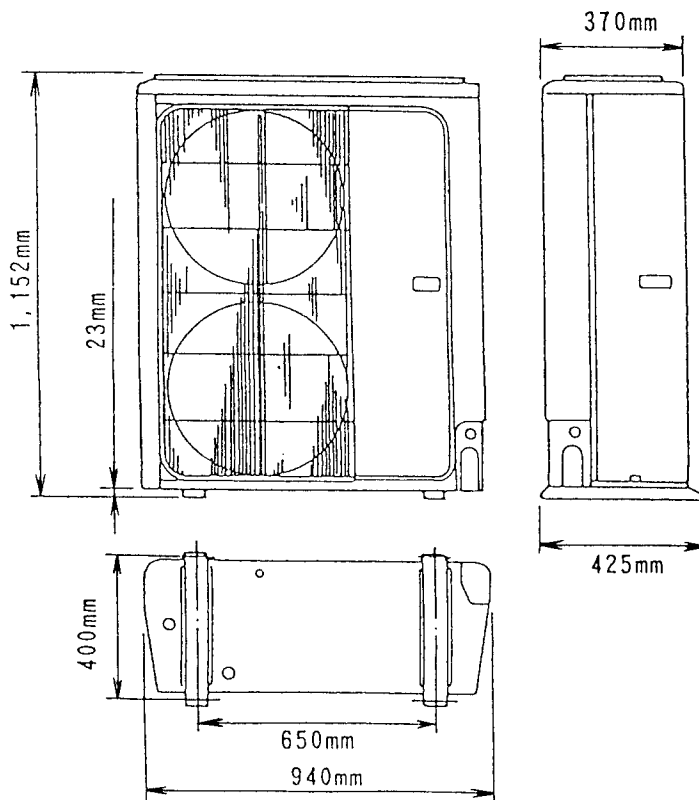
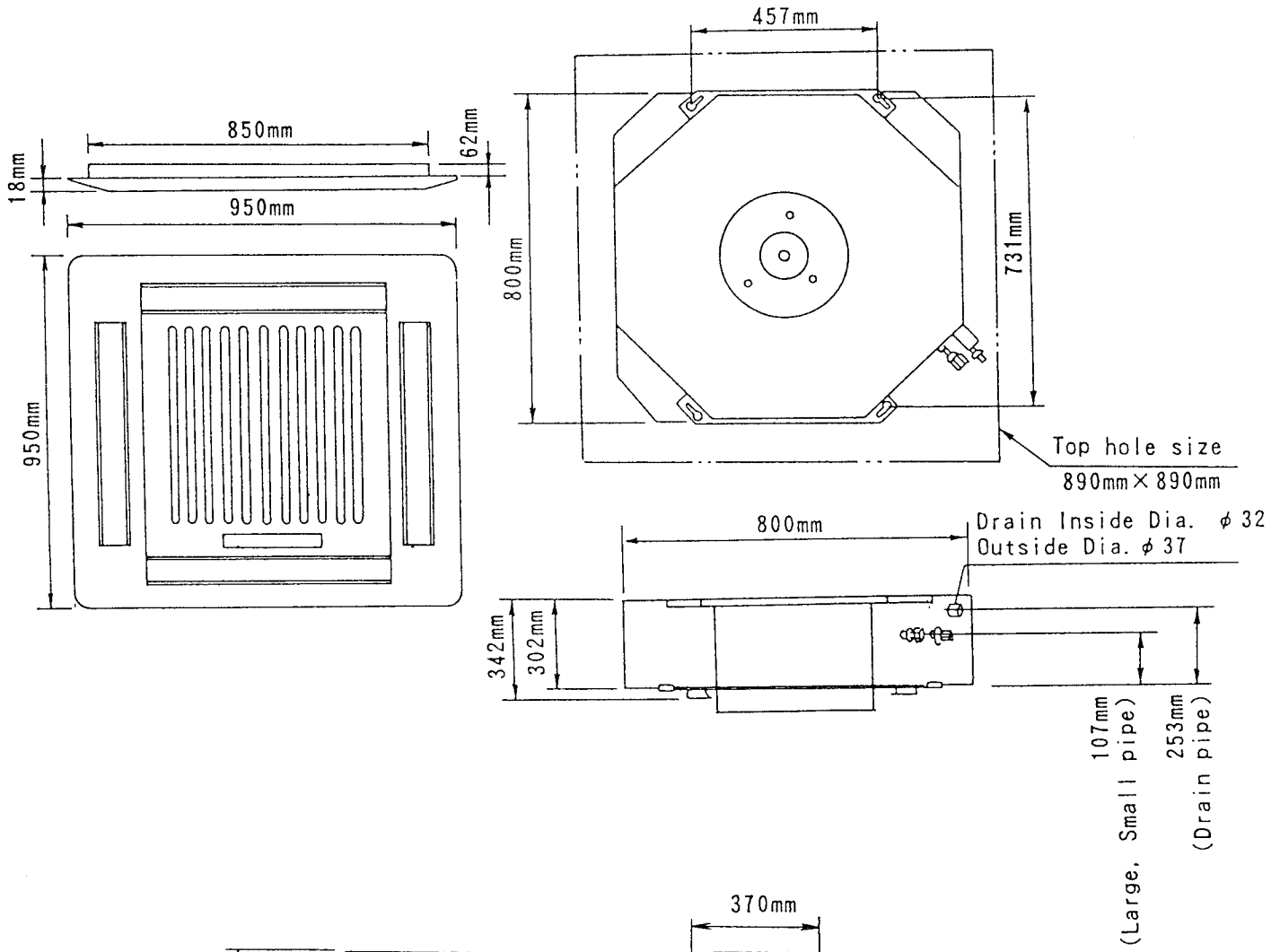

C I R C U I T D I A G R A M

Models : RCW-18
 RCW-25
 RCW-36
 RCW-45

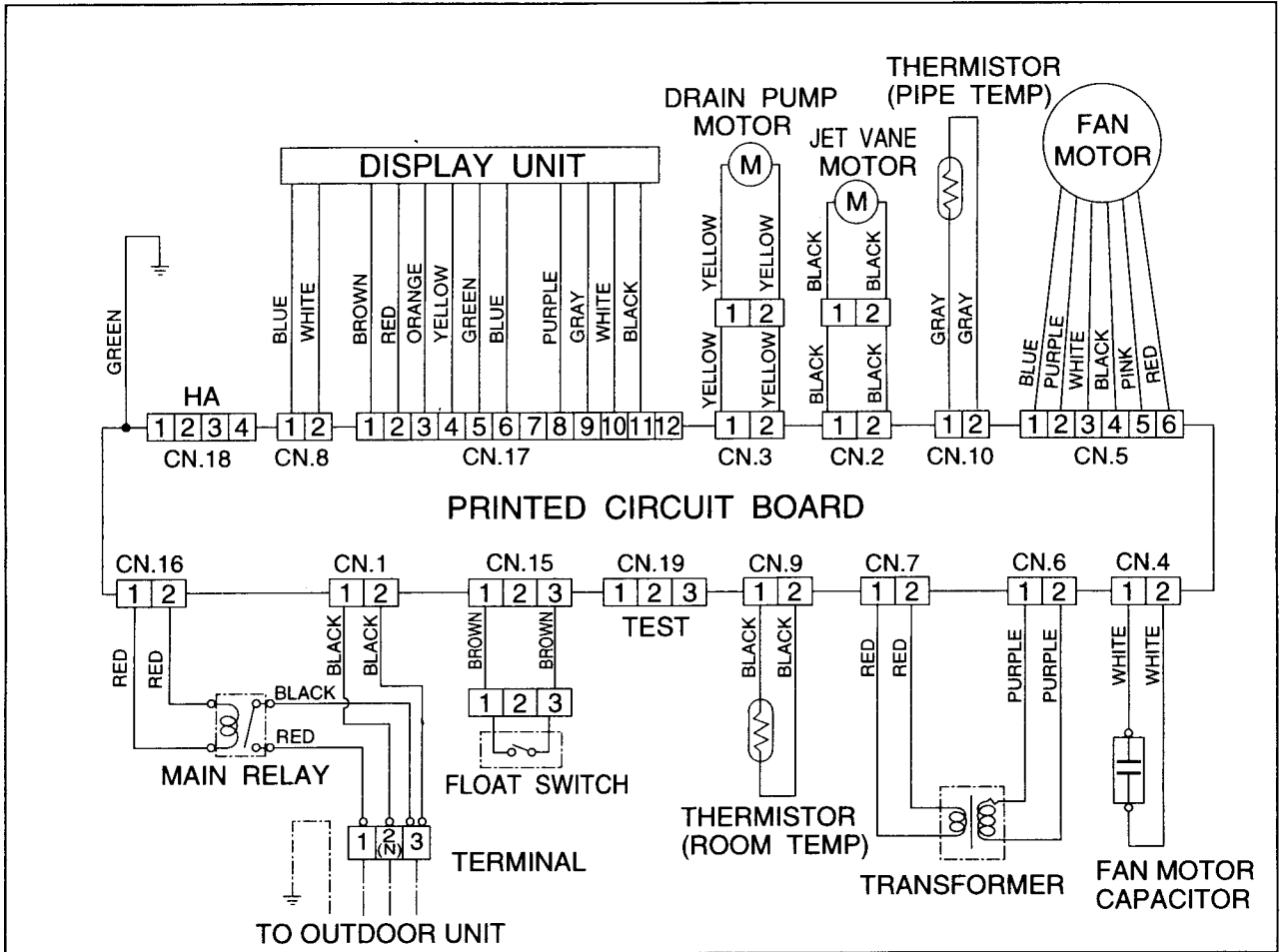

Models : ROCW-18
 ROCW-25

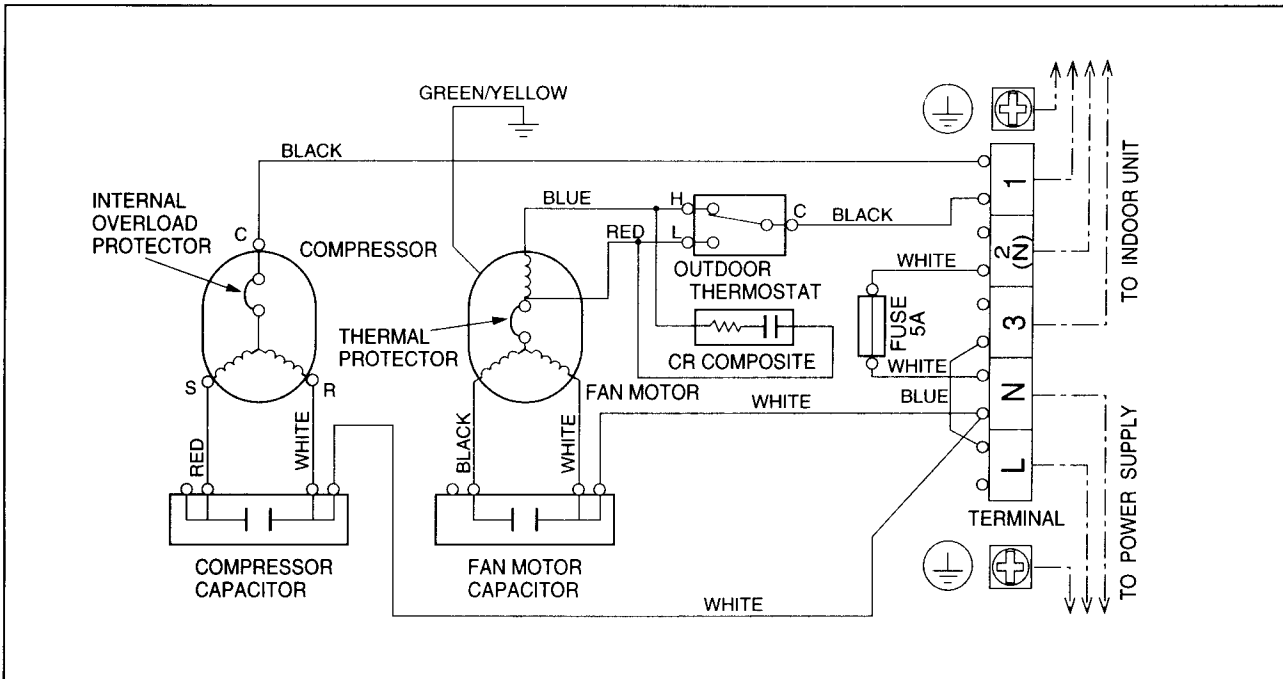

Models : ROCW-367
 ROCW-457

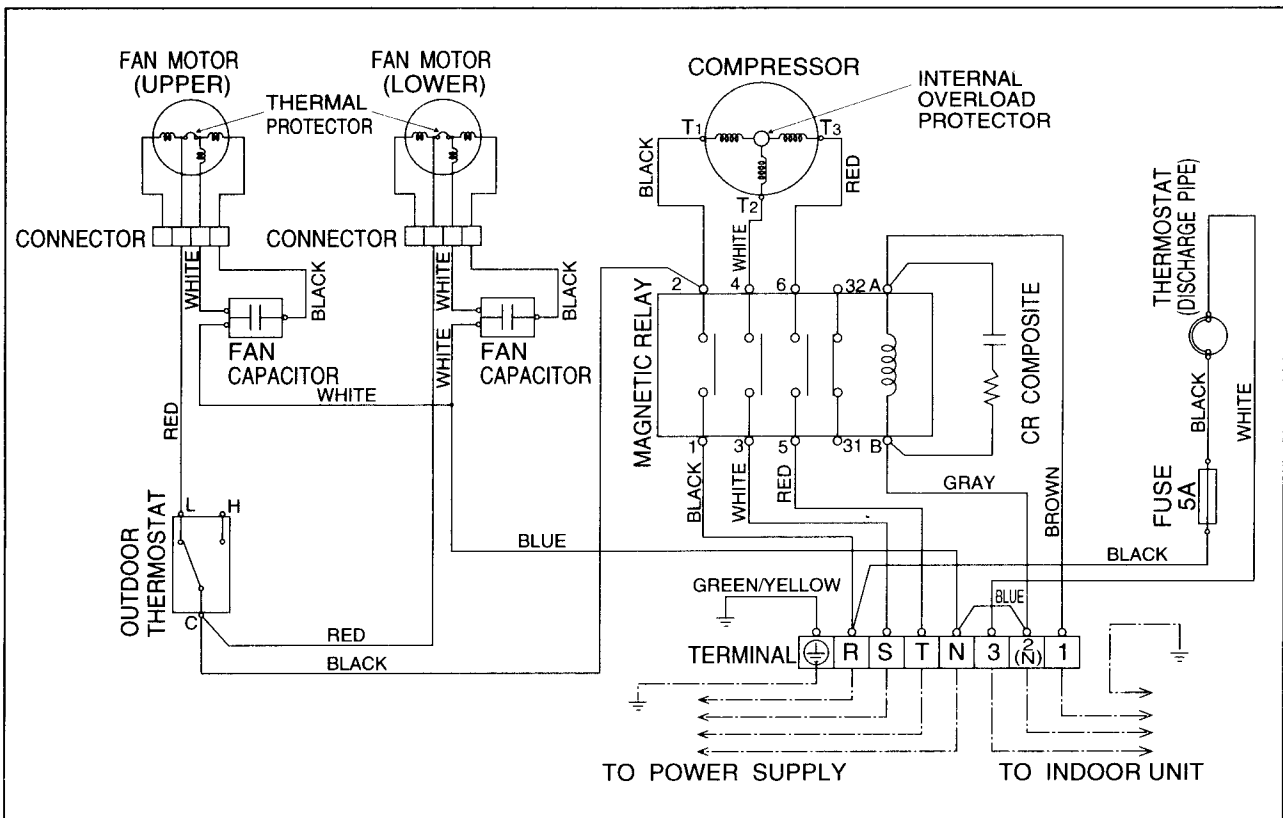

Models : RCW-18
 RCW-25
 RCW-36
 RCW-45

INDOOR PRINTED CIRCUIT BOARD

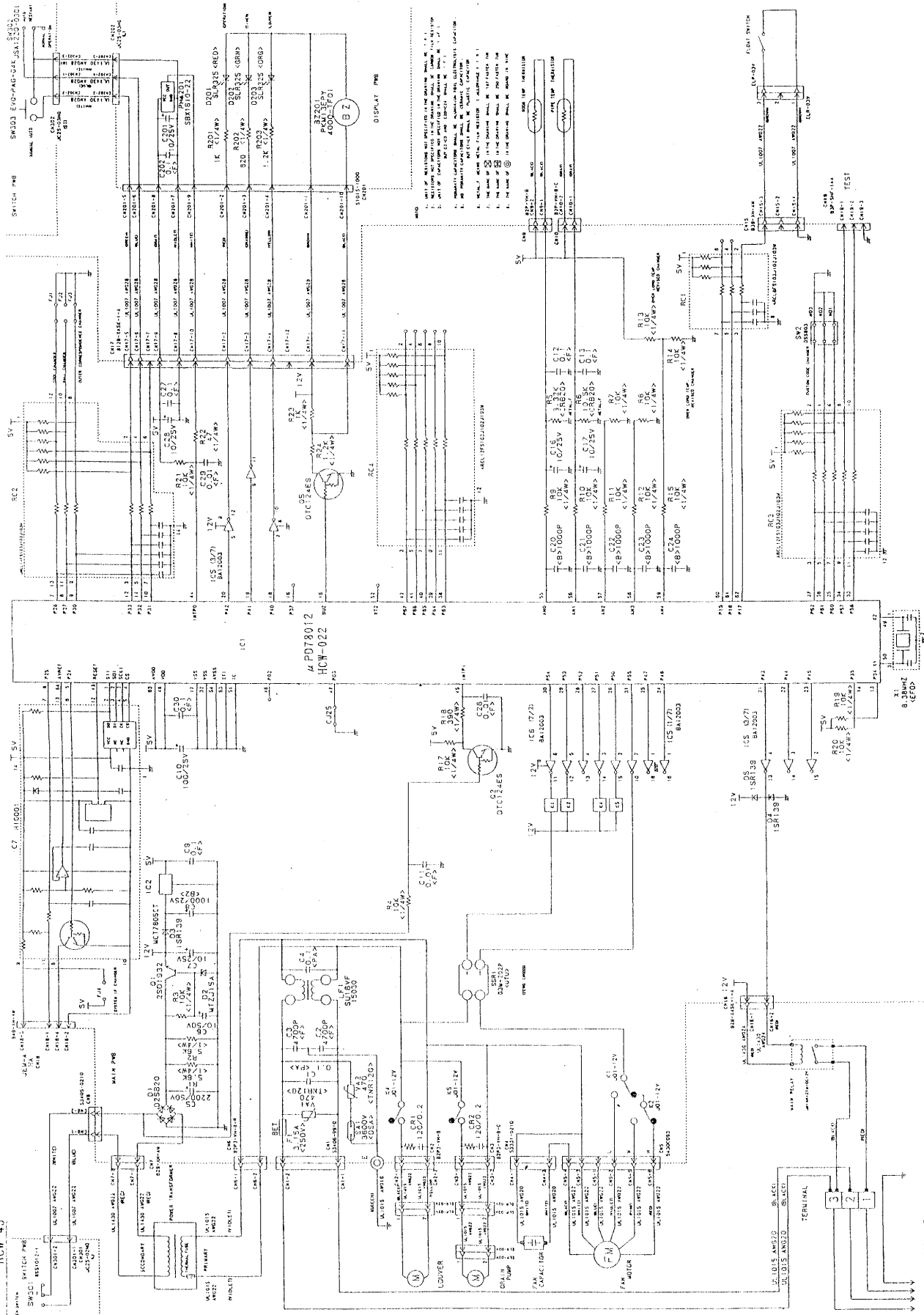

P. C. BOARD LAYOUTS

(VIEWED FROM THE SOLDER SIDE)

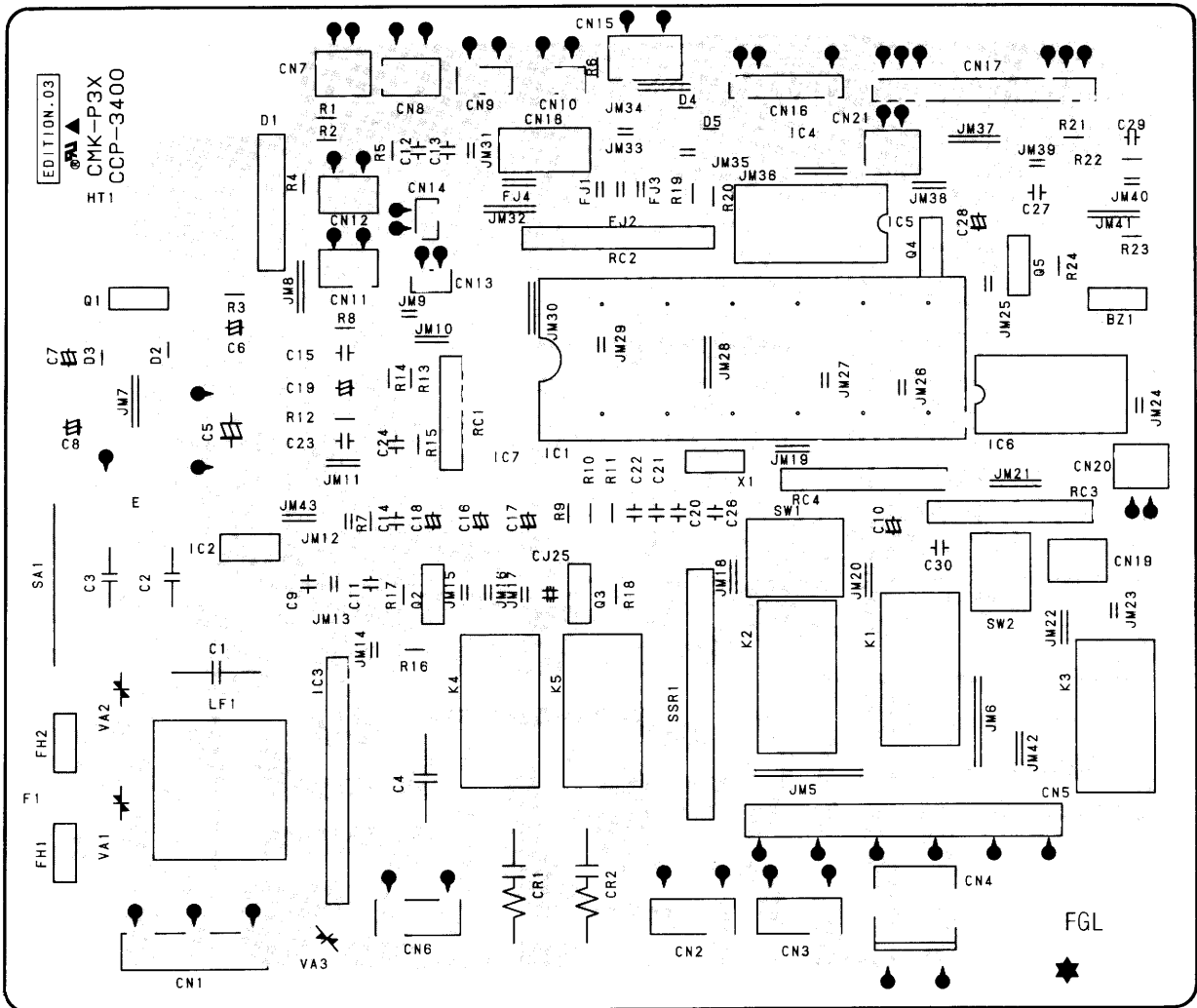

SWITCH P. C. BOARD OVERLAY

(VIEWED FROM THE SOLDER SIDE)

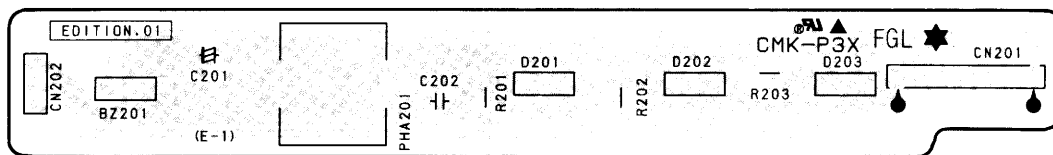
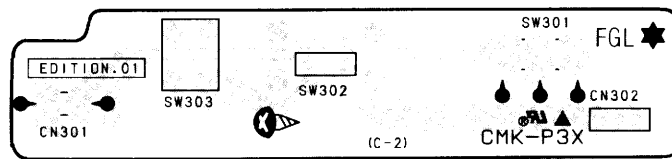

REMOTE CONTROLLER CIRCUIT DIAGRAM

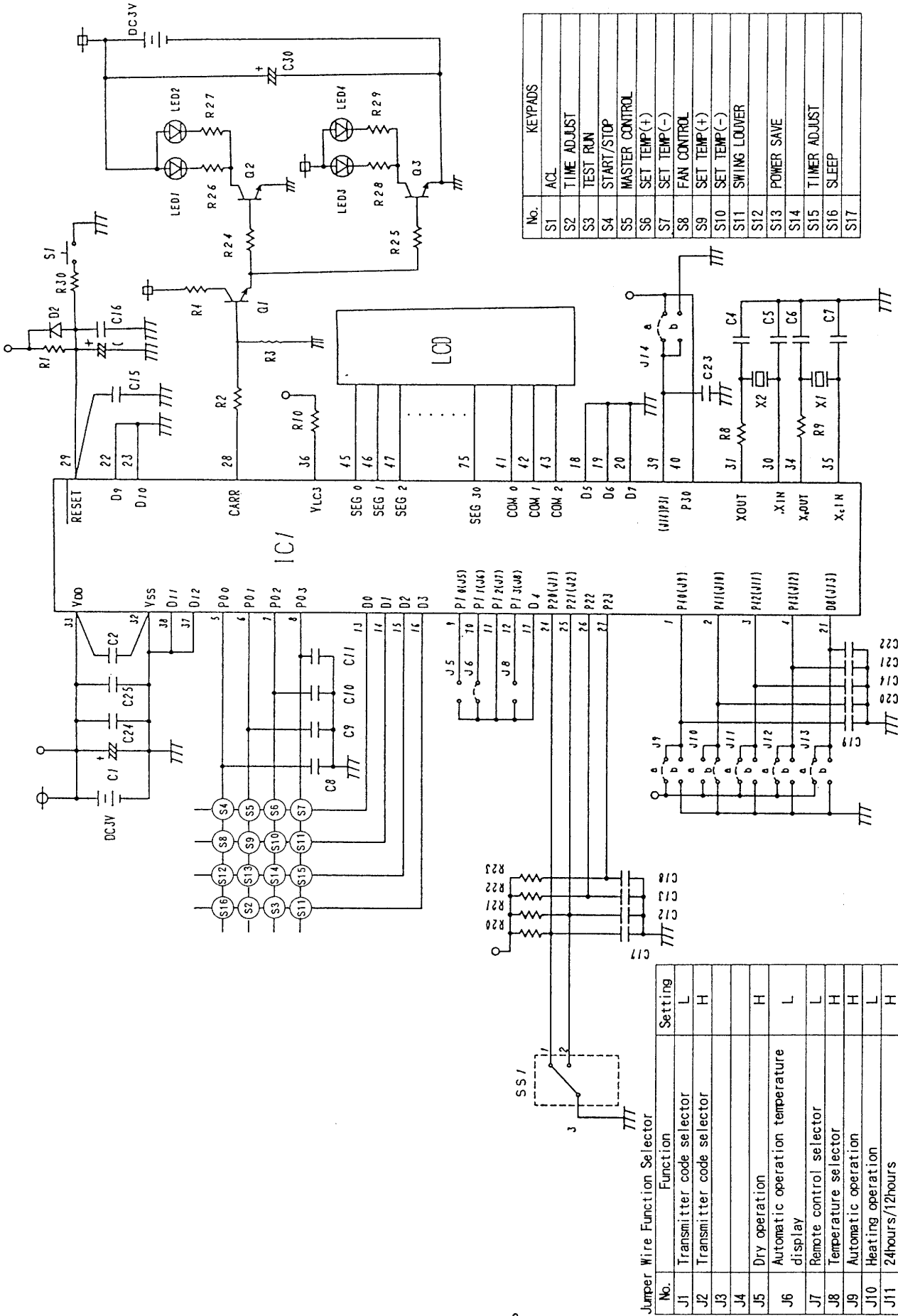

No.	KEYPADS
S1	ACL
S2	TIME ADJUST
S3	TEST RUN
S4	START/STOP
S5	MASTER CONTROL
S6	SET TEMP(+)
S7	SET TEMP(-)
S8	FAN CONTROL
S9	SET TEMP(+)
S10	SET TEMP(-)
S11	SWING LOUVER
S12	
S13	POWER SAVE
S14	
S15	TIMER ADJUST
S16	SLEEP
S17	

No.	Function	Setting
J1	Transmitter code selector	L
J2	Transmitter code selector	H
J3		
J4		
J5	Dry operation	H
J6	Automatic operation temperature display	L
J7	Remote control selector	L
J8	Temperature selector	H
J9	Automatic operation	H
J10	Heating operation	L
J11	24hours/12hours	H
J12	Super quiet	H
J13	Automatic operation display selector	H
J14	Fan mode	H

L: Connected to ♂
H: Connected to ♀

REFRIGERANT SYSTEM DIAGRAM

Models : RCW-18/ROCW-18

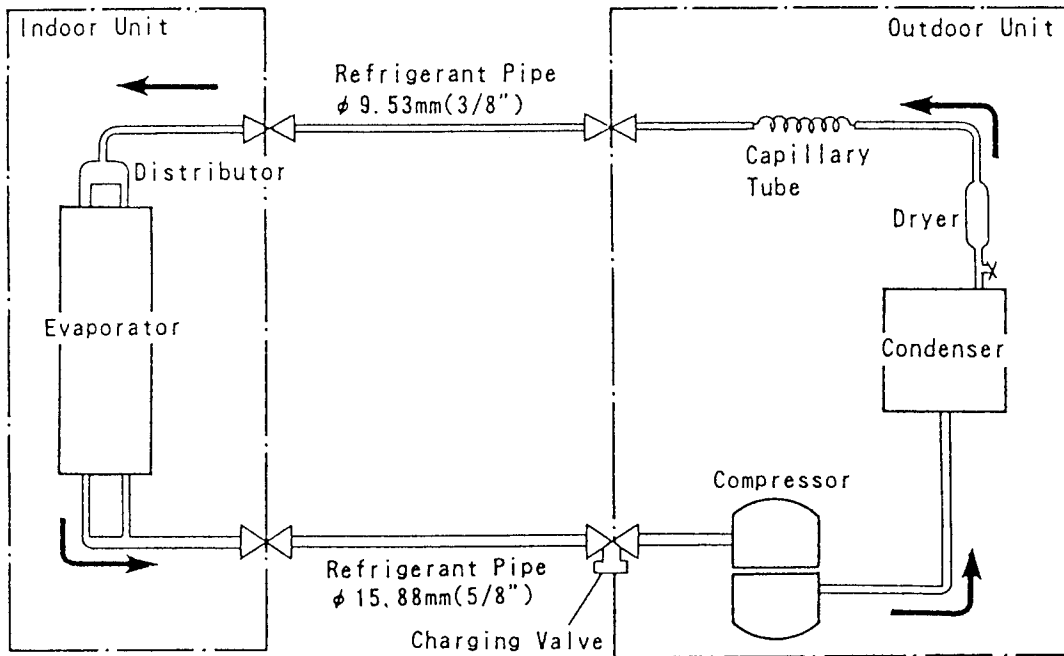

Models : RCW-25/ROCW-25

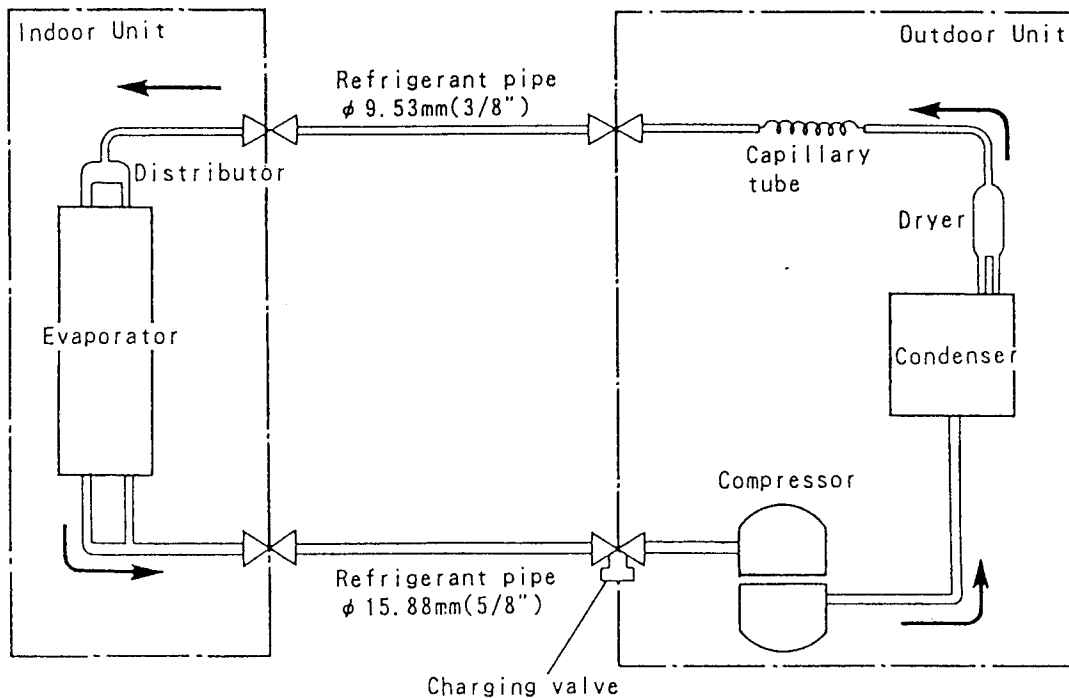

 Cooling
 : Flare coupling

Models : RCW-36/R0CW-367

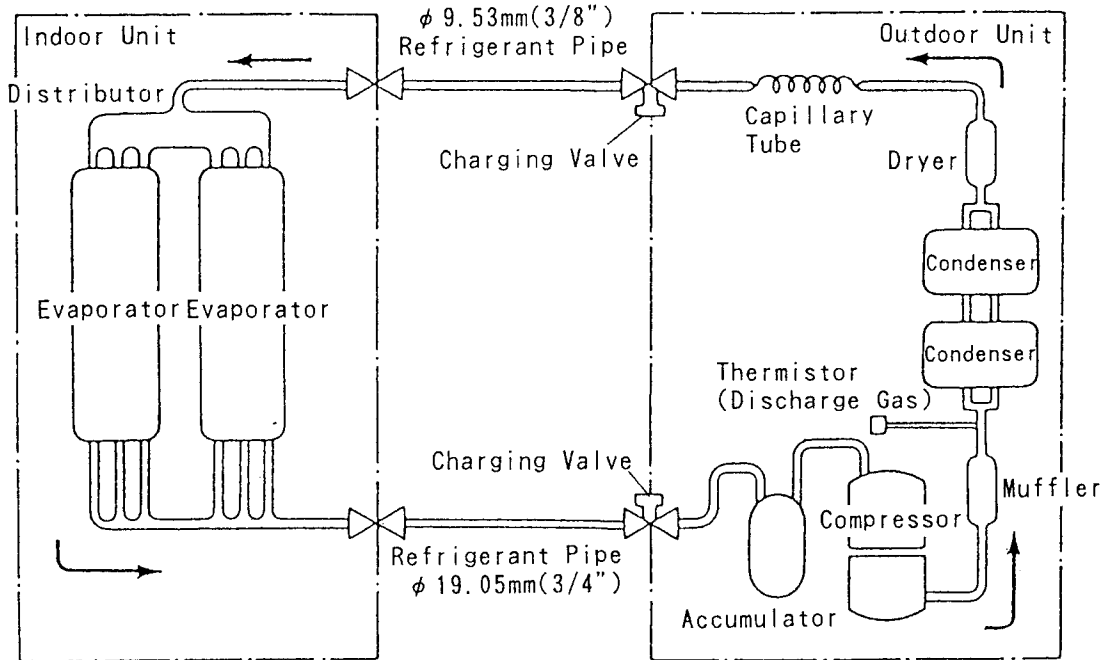

Models : RCW-45/R0CW-457

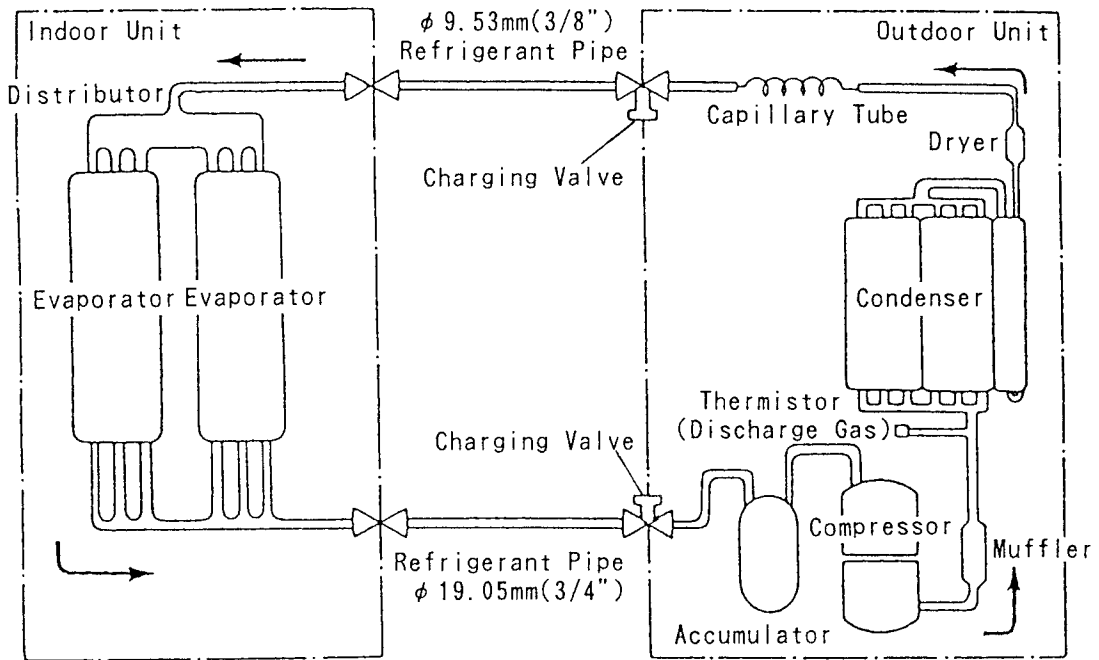

→ Cooling

⊗ : Flare coupling

DISASSEMBLY ILLUSTRATION

Model : CG-6C

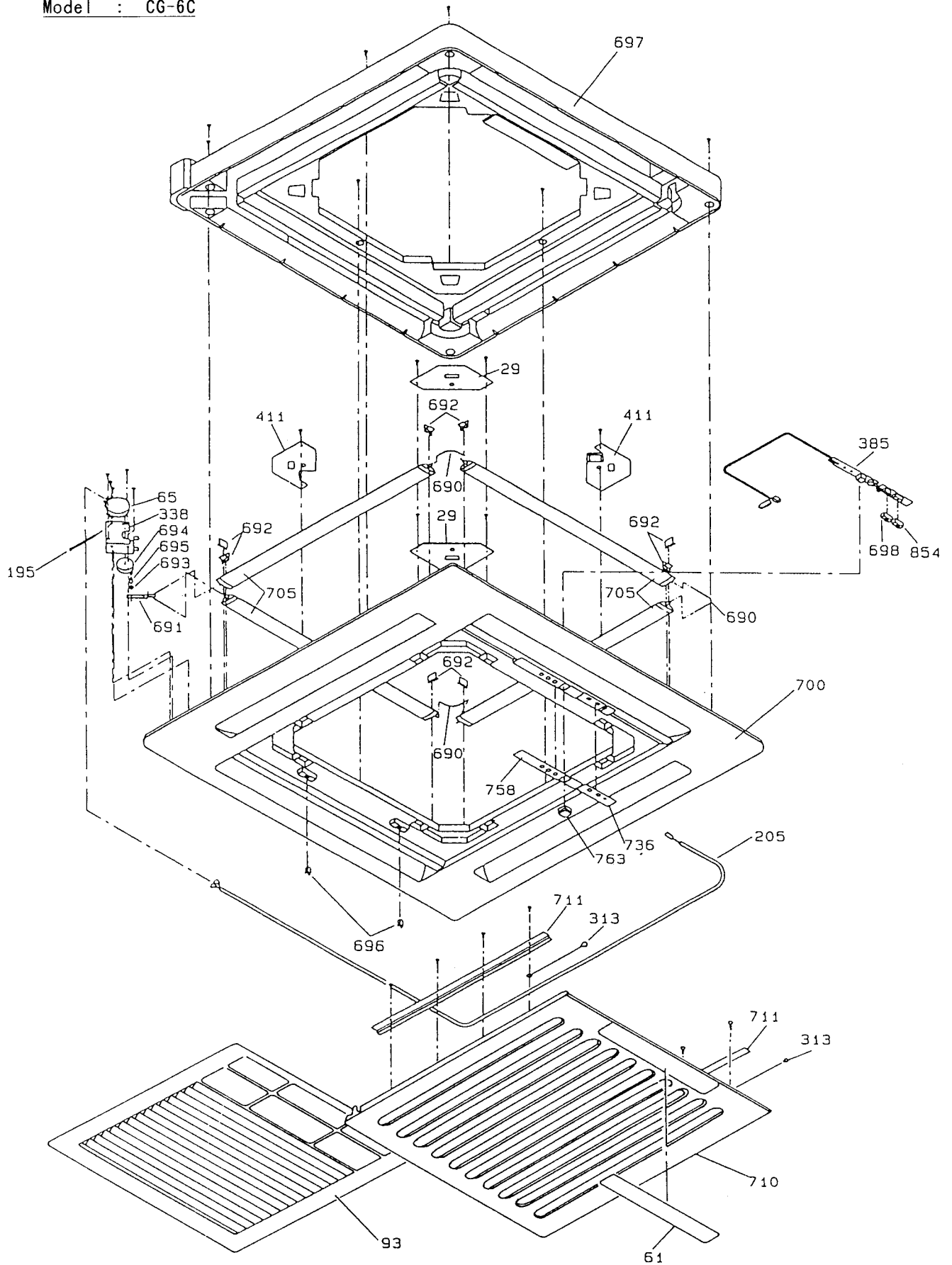

Models : RCW-18
RCW-25

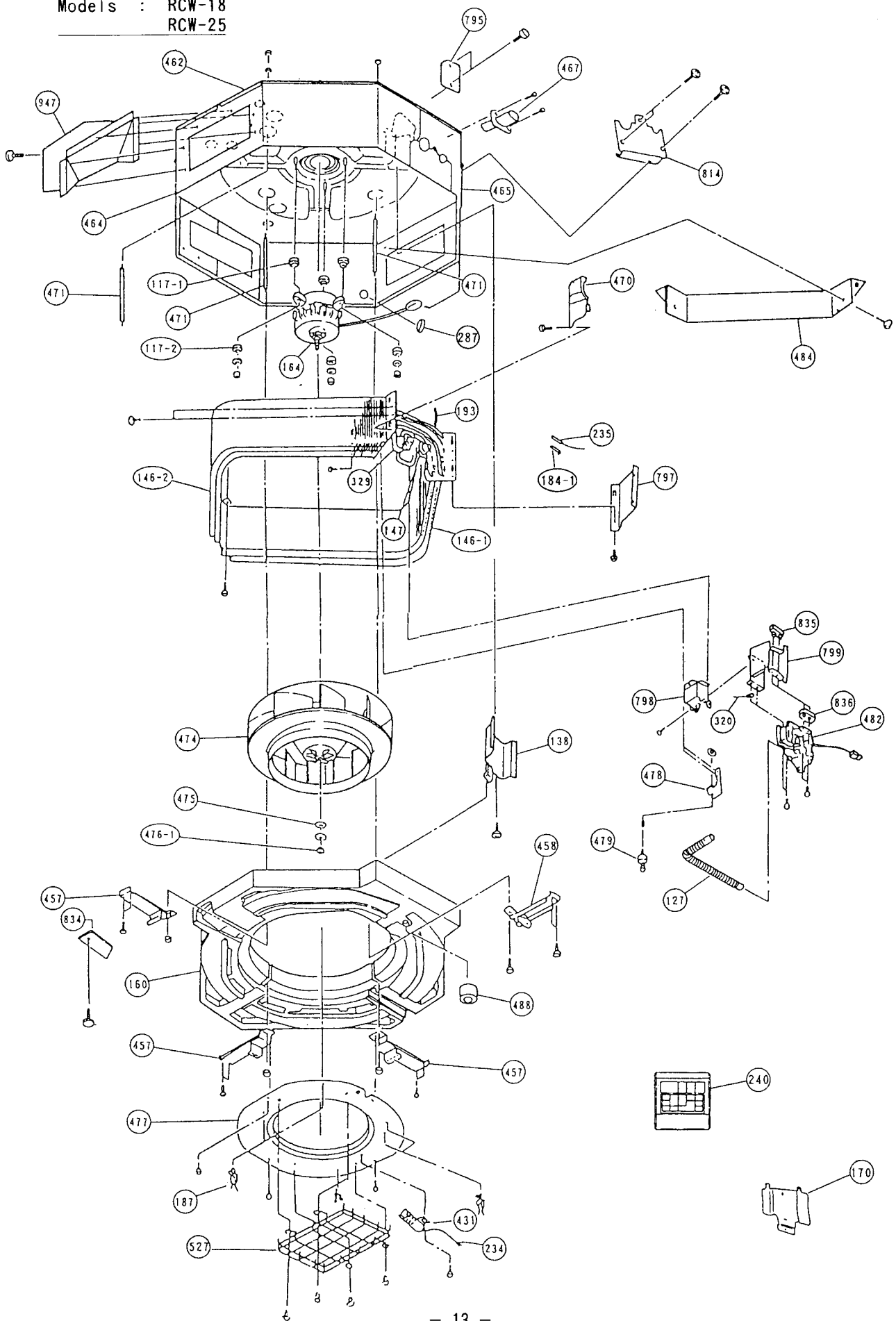

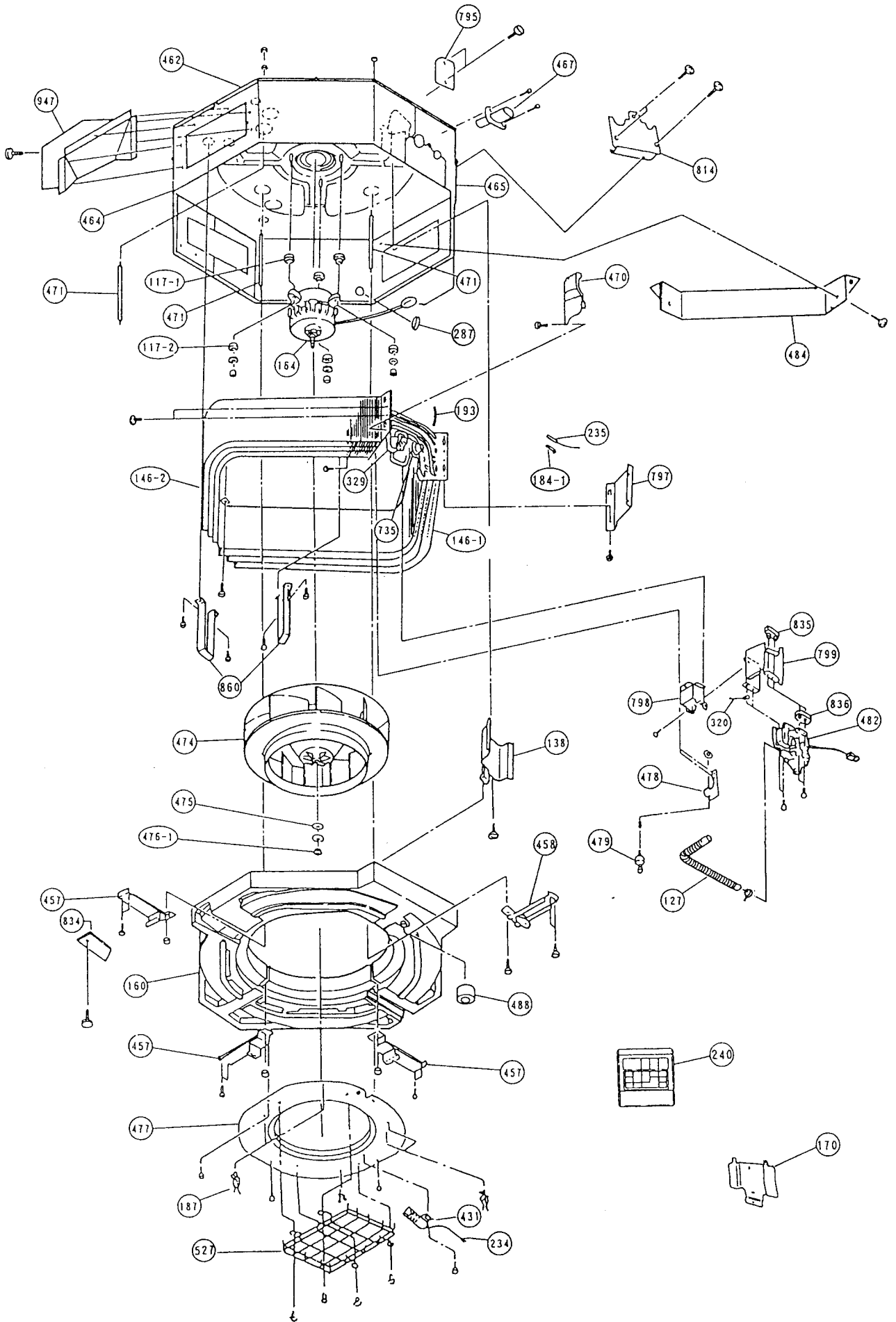

Models : RCW-18
 RCW-25
 RCW-36
 RCW-45

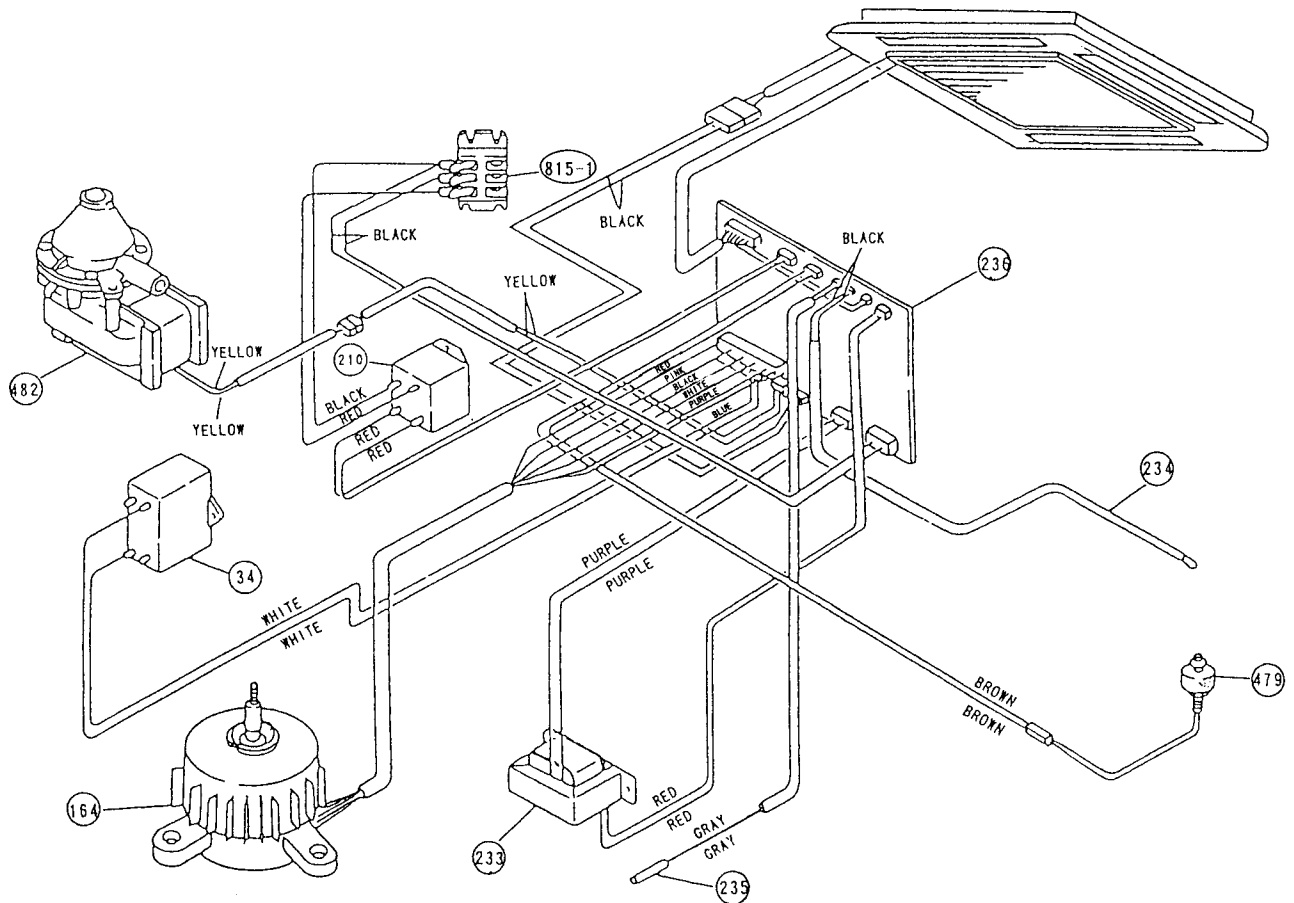
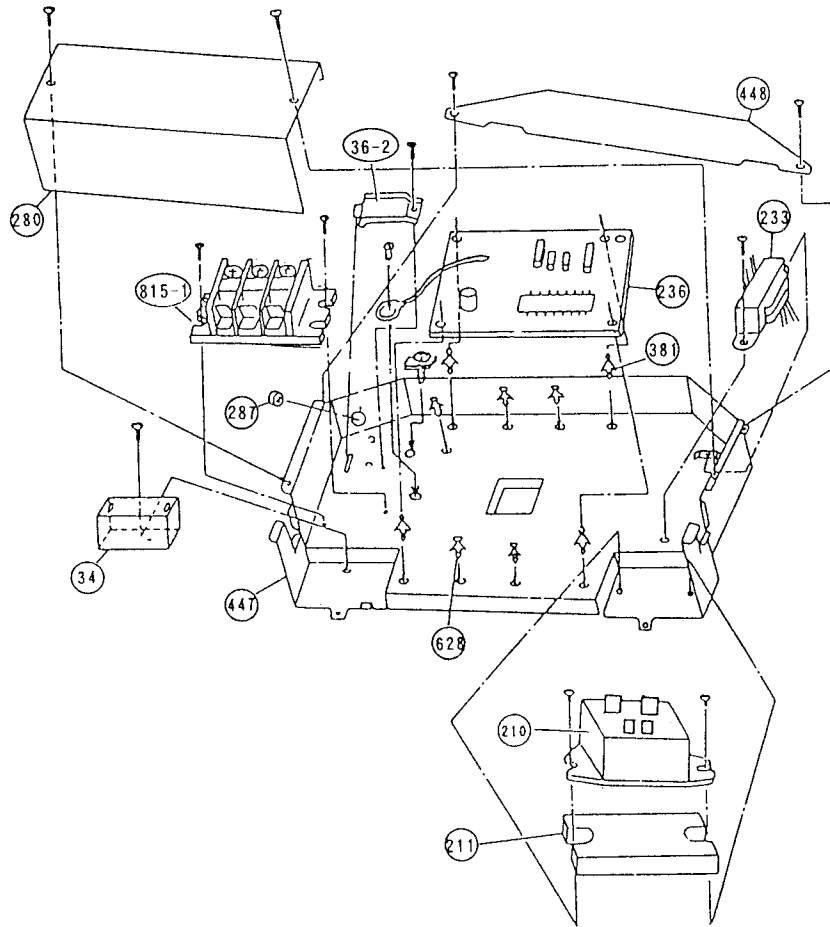

Models : ROCW-18
ROCW-25

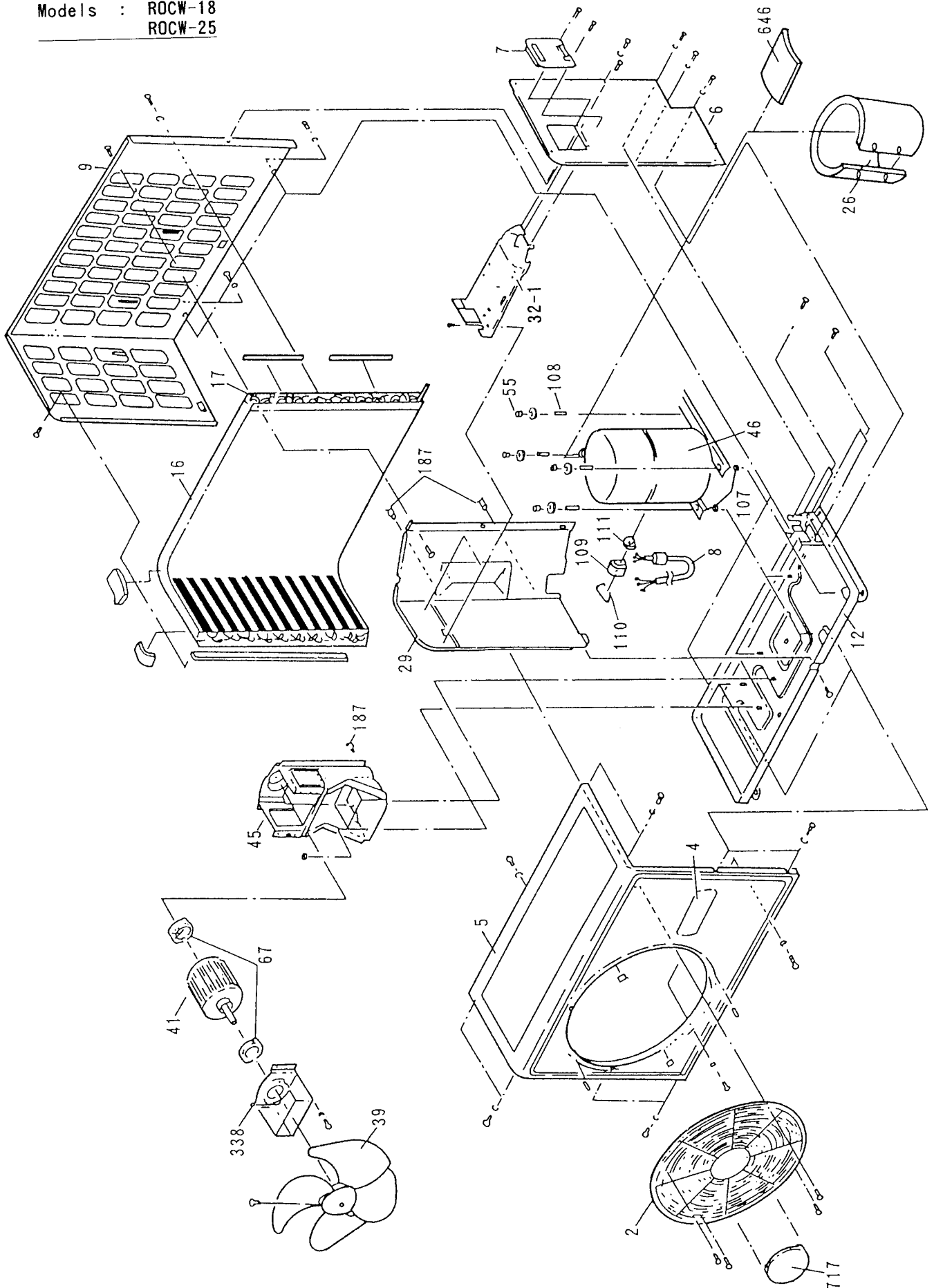

Model : ROCW-18

Model : ROCW-25

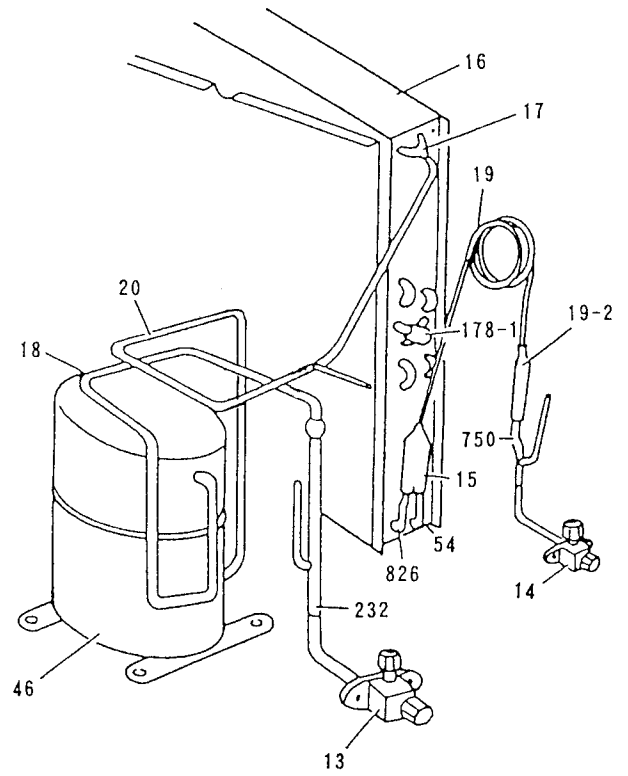
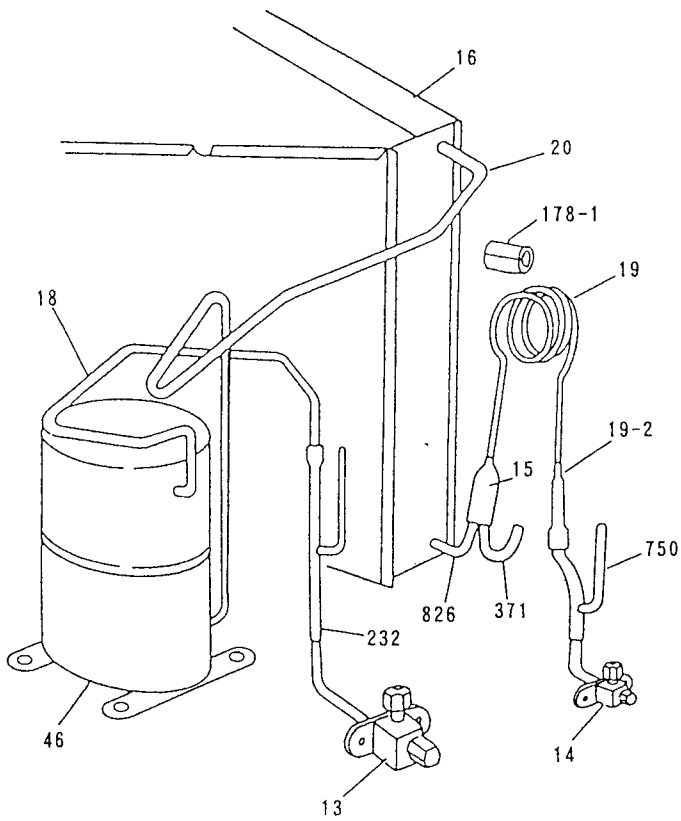

Models : ROCW-18
ROCW-25

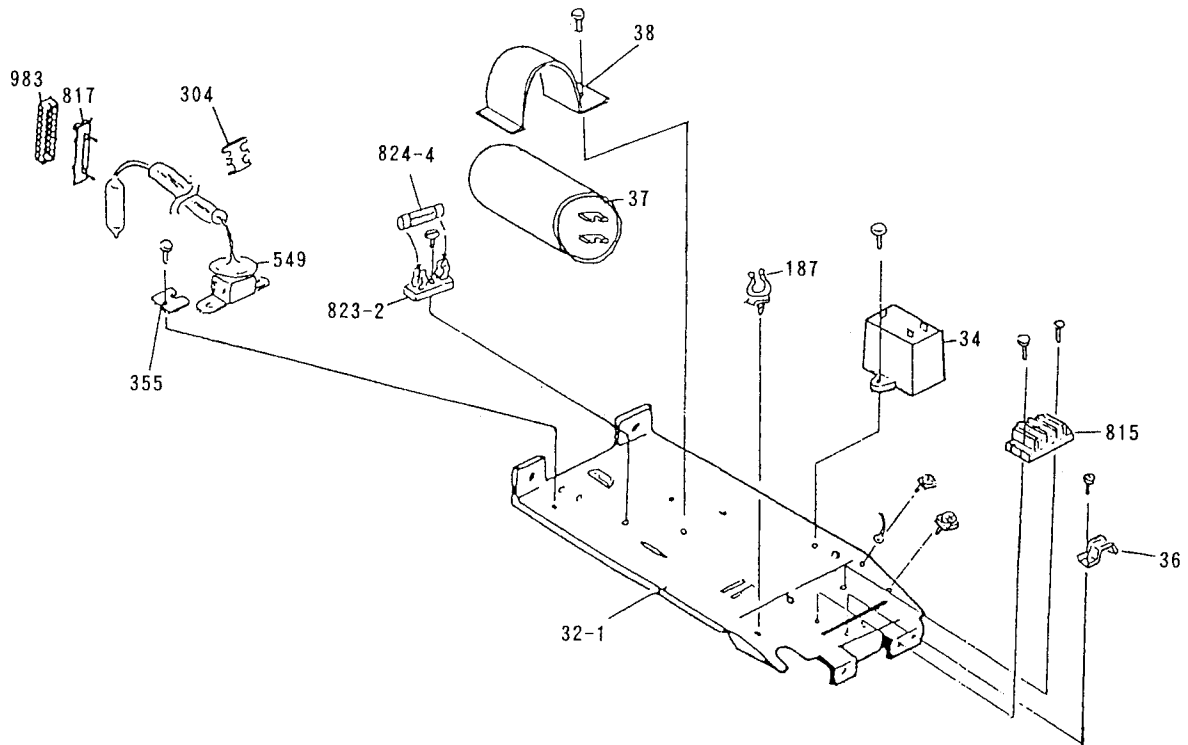

Models : ROCW-367
ROCW-457

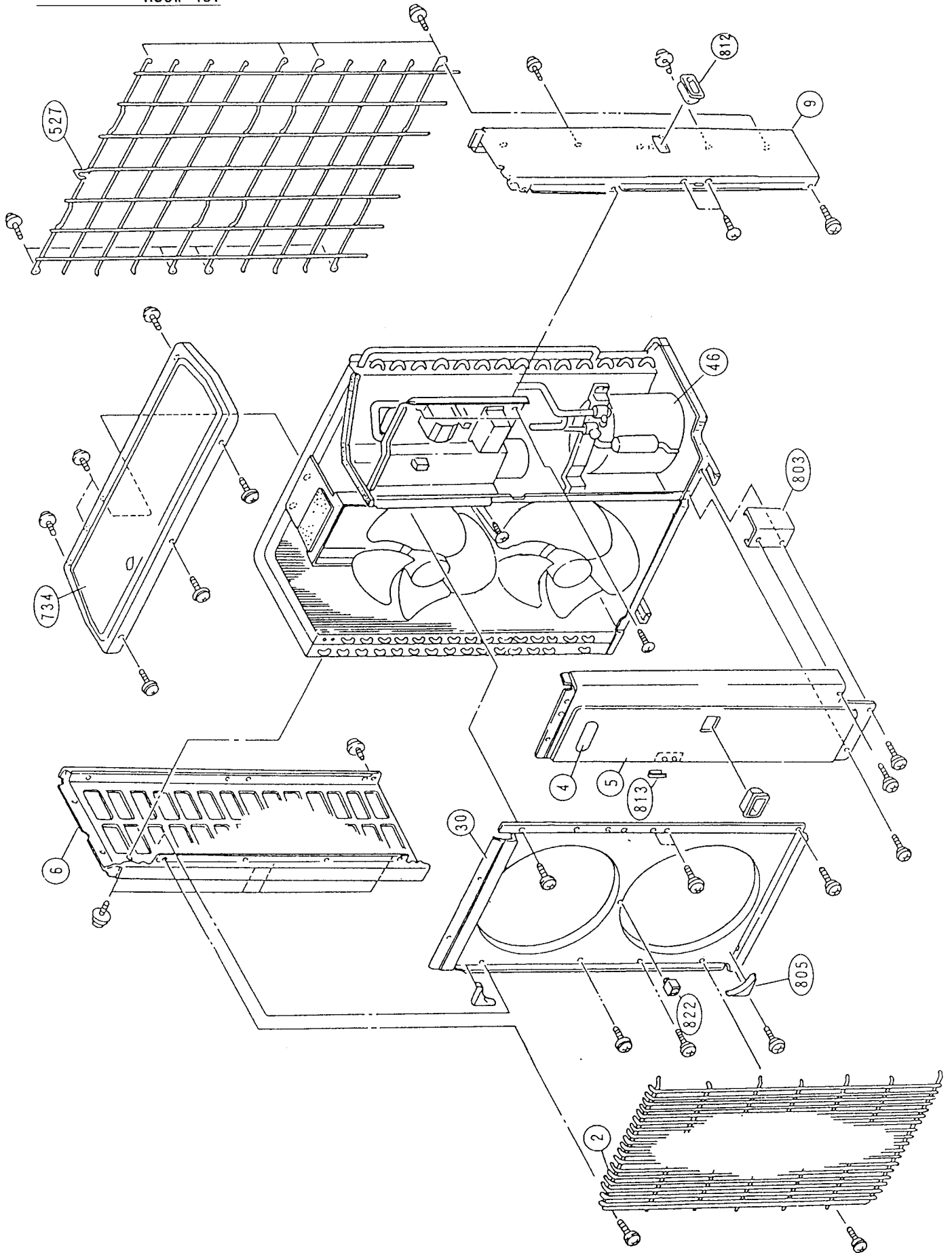

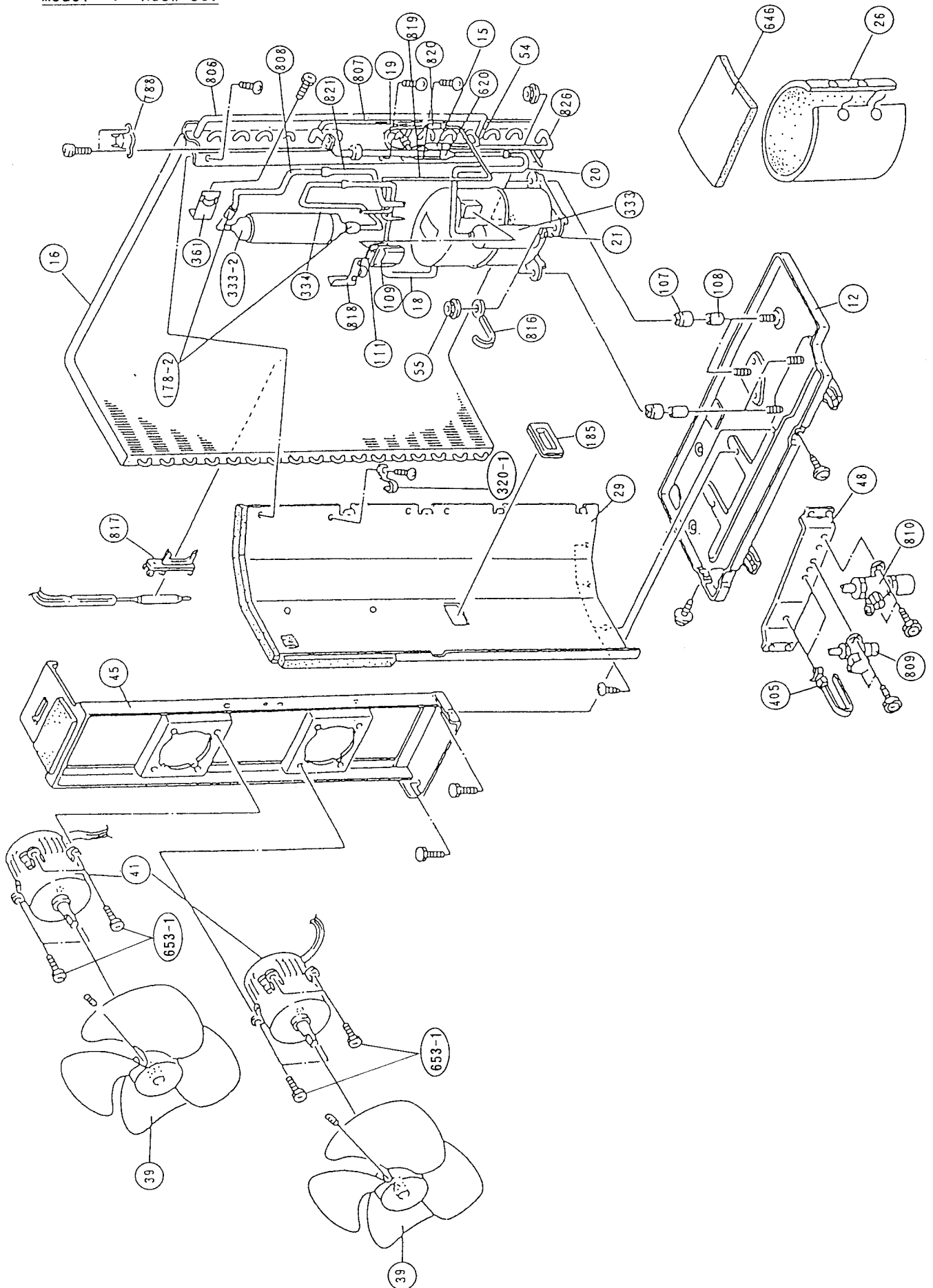

Model : ROCW-457

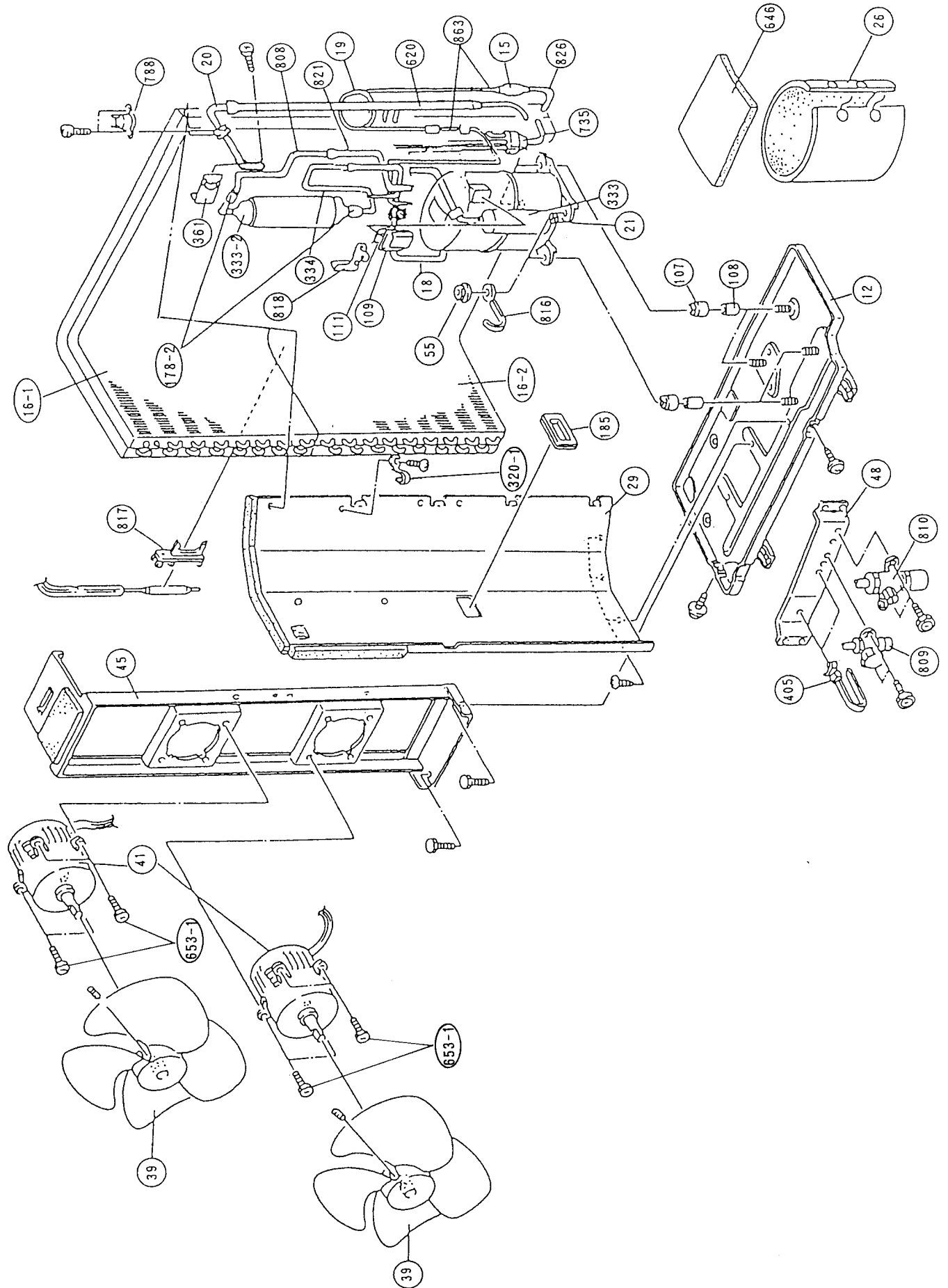

Models : ROCW-367
ROCW-457

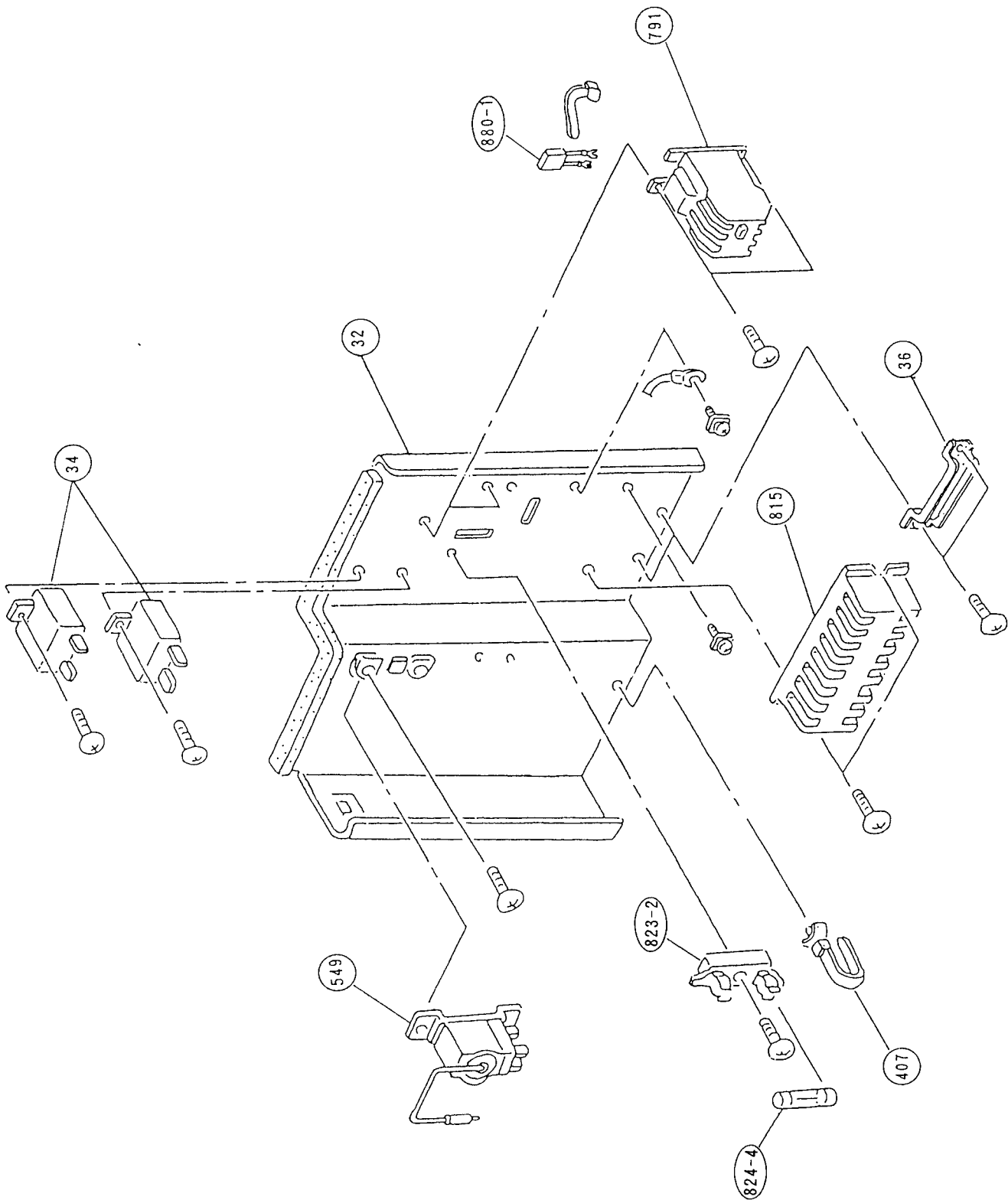

PARTS LIST

When you order parts, please make a photocopy of this page and fill the number of the parts in the "Order" column.

OUTDOOR UNIT

Ref. No.	Description	Part No.				Order
		ROCW-18	ROCW-25	ROCW-367	ROCW-457	Q'ty
2	Fan Cover	9350214020	9350214020	9352159015	9352159015	
4	Emblem-Rear	9301702019	9301702019	9301702019	9301702019	
5	Cabinet-A, Painted	9303876015	9303876015	9352146015	9352146015	
6	Cabinet-C, Painted	9353549013	9353549013	9352149016	9352149016	
7	Connector Cover	9358011010	9358011010	-	-	
8	Wire Assy (Shield)-D	9350215010	9350215027	-	-	
9	Cabinet-B, Painted	9303874011	9303874011	9352147012	9352147012	
12	Base Assy, Painted	9353452016	9353452016	9352136016	9352136016	
13	3-Way Valve Assy	9357963013	9357963013	-	-	
14	2-Way Valve Assy	9357964010	9357964010	-	-	
15	Dryer	313791082502	9355465007	9300589031	9353789006	
16	Condenser Assy	9353455055	9353455017	9352128011	-	
16-1	Condenser-A Assy	-	-	-	9355338011	
16-2	Condenser-B Assy	-	-	-	9353363008	
17	"U" Pipe-Y	-	313728127102	-	-	
18	Suction Pipe	9360518002	9355617000	9352286001	9353200006	
19	Capillary Tube	9354267008	9355464000	9352439001	9353644008	
19-2	Joint Pipe	9354268005	9354268005	-	-	
20	Discharge Pipe Assy	-	9360636003	-	9353620002	
20	Discharge Pipe	9360522009	-	9352288005	-	
21	Discharge Pipe-B	-	-	9352289002	9353209009	
26	Compressor Cover	9354036000	9354036000	-	-	
26	Compressor Cover-A	-	-	9352416002	9353367006	
29	Separate Wall	313986033213	313986033213	9355277013	9355277013	
30	Blower Cover, Painted	-	-	9352151019	9352151019	
32	Control Box Metal	-	-	9352134012	9352134012	
32-1	Control Box Metal-A	9353595003	9353595003	-	-	
34	Capacitor (Fan Motor)	9357965024	9357965024	9357965024	9357965024	
36	Cord Holder Metal	9356934007	9356934007	9356934007	9356934007	
37	Running Capacitor	9357211015	9357211015	-	-	
38	Capacitor Clamp Metal	313791061807	313791061807	-	-	
39	Propeller Fan Assy	9300855013	9300855013	9300855013	9300855013	
41	Fan Motor Assy-Out	9351333041	9351333041	9600266014	9600266014	
45	Bracket(Motor) Assy	313029311100	313029311100	9352141003	9352141003	
46	Compressor Assy	9360509055	9360509017	9352412004	9353157003	
48	Bracket(Coupler) Assy	-	-	9355281010	9355281010	
54	Condensing Pipe	-	9300557016	-	-	
54	Condensing Pipe-A	-	-	9352296000	-	
55	Special Nut M8	313252257701	313252257701	313252257701	313252257701	
67	Rubber (Vibration Proof)	313659068604	313659068604	-	-	
107	Rubber Seat-A(For Comp.)	313093081402	313093081402	9351875039	9351875039	
108	Sleeve-A (For Comp.)	313093081706	313093081706	9351875046	9351875046	
109	Terminal Cover	313202059600	313202059600	9351875053	9351875053	
110	Lock Wire	313202059706	313202059706	-	-	
111	Terminal Packing	313202059807	313202059807	9351875060	9351875060	
178-1	Capillary Holder Rubber	313414274807	313414274807	-	-	
178-2	Capillary Holder Rubber	-	-	313394274808	313394274808	
185	Rubber Bushing	-	-	313005066051	313005066051	
187	Clamp No. 1219	313361271706	313361271706	-	-	

ROCW-18
 ROCW-25
 ROCW-367
 ROCW-457

When you order parts, please make a photocopy of this page and fill the number of the parts in the "Order" column.

OUTDOOR UNIT (Continued)

Ref. No.	Description	Part No.				Order
		ROCW-18	ROCW-25	ROCW-367	ROCW-457	Q'ty
232	Pipe Assy	9354269002	9300990028	—	—	
304	Thermostat Fixture-B	313349051500	313349051500	—	—	
320-1	Wire Clamp Metal	—	—	313483219905	313483219905	
333	Accumulator	—	—	9350363018	9350363018	
333-2	Accumulator(B)	—	—	9301942019	9301942019	
334	Suction Pipe-B	—	—	9352557002	9352557002	
338	Motor Fixture Metal	313029297108	313029297108	—	—	
355	Switch Bracket	313986353607	313986353607	—	—	
361	Accumulator Support Assy	—	—	9355351003	9355351003	
371	Process Pipe-B	313142082352	—	—	—	
405	Clamp No.1763	—	—	313816345304	313816345304	
407	Clip (Cable) No.1259	—	—	313739340109	313739340109	
527	Protection Net	—	—	9352163012	9352163012	
549	Thermostat-Outdoor	9352553004	9352553004	9352426001	9352426001	
620	Inlet Pipe (Cond.) Assy	—	—	9355316019	9353183002	
646	Compressor Cover-B	313986355101	313986355101	313986355101	9353368003	
653-1	Bolt (Fan Motor Fixing)	—	—	0700156014	0700156014	
717	Center Plate	9351253011	9351253011	—	—	
734	Cabinet Top Plate	—	—	9352161018	9352161018	
735	Distributor Assy	—	—	—	9353187000	
750	Pipe-A Assy	9301003017	9301003017	—	—	
788	Thermostat-Overheat	—	—	9354061002	9354061002	
791	Magnetic Relay	—	—	9352552007	9352552007	
803	Cabinet-D, Painted	—	—	9352150012	9352150012	
805	Blower Cover Corner	—	—	9352160011	9352160011	
806	Cond. Pass Pipe-A	—	—	9352294006	—	
807	Cond. Pass Pipe-B Assy	—	—	9353090010	—	
808	Inlet Pipe (Accumulator)	—	—	9352556005	9352556005	
809	Ball Valve-A	—	—	9357976006	9357976006	
810	Ball Valve-B	—	—	9357982007	9357982007	
812	Grip	—	—	9352157004	9352157004	
813	Cabinet Hook	—	—	9352148002	9352148002	
815	Terminal-8P	—	—	9358640029	9358640029	
815	Terminal-5P	9356497021	9356497021	—	—	
816	Wire Clamp Metal	—	—	313584219902	313584219902	
817	Thermostat Fixture	9352164019	9352164019	9352164019	9352164019	
818	Accumulator Support-B Assy	—	—	9355350006	9355350006	
819	Valve-A Coupl. Pipe	—	—	9352298004	—	
820	Joint Pipe (Capillary)	—	—	9352299001	—	
821	Joint Pipe Assy	—	—	9352284007	9352284007	
822	Fan Cover Fixture-A	—	—	9352158018	9352158018	
823-2	Fuse Holder	0500063024	0500063024	0500063024	0500063024	
824-4	Fuse	0600222529	0600222529	0600222529	0600222529	
826	Condensing Pipe-B	9353601001	9300558013	9352297007	9353215000	
863	Joint Pipe(Capillary)-B	—	—	—	9353206008	
880-1	Network	—	—	9700987017	9700987017	
983	Thermostat Cover	9358274002	9358274002	—	—	

When you order parts, please make a photocopy of this page and fill the number of the parts in the "Order" column.

INDOOR UNIT

Ref. No.	Description	Part No.				Order Q'ty
		RCW-18	RCW-25	RCW-36	RCW-45	
34	Capacitor (Fan Motor)	9700468080	9357965017	9700467052	9700467069	
36-2	Cord Holder Metal	9356362008	9356362008	9356362008	9356362008	
117-1	Rubber-A	313005068754	313005068754	9352213007	9352213007	
117-2	Rubber-B	313005068855	313005068855	313005068855	313005068855	
127	Drain Hose	9352210013	9352210013	9352210020	9352210020	
138	Separate Wall	9355637039	9355637039	9355637015	9355637015	
146-1	Evaporator-A Assy	9356651003	9356652000	9356059007	9356059007	
146-2	Evaporator-B Assy	9356650006	9356653007	9356060003	9356060003	
147	Inlet Pipe(Eva.) Assy	9355371032	9355371032	—	—	
160	Drain Pan Assy	9357882000	9357882000	9357882000	9357882000	
164	Fan Motor Assy-IN	9600451014	9600451014	9600398029	9600398012	
170	Remote Control Bracket	9358795002	9358795002	9358795002	9358795002	
184-1	Thermistor Spring-A	313728262708	313728262708	313728262708	313728262708	
187	Clamp No.1219	313361271706	313361271706	313361271706	313361271706	
193	Cushion (Rubber)	313376149201	313376149201	313376149201	313376149201	
210	Main Relay	9356781007	9356781007	9356781007	9356781007	
211	Cushion Rubber	313806328306	313806328306	313806328306	313806328306	
233	Power Transformer	9701343010	9701343010	9701343010	9701343010	
234	Thermistor Assy	9302745008	9302745008	9302745008	9302745008	
235	Thermistor Assy-Pipe	9701329045	9701329045	9701329045	9701329045	
236	Controller PCB Assy	9702332013	9702332013	9702332013	9702332013	
240	Remote Control Unit	9358650042	9358650042	9358650042	9358650042	
280	Control Box Metal-C	9355636001	9355636001	9355636001	9355636001	
287	Cap (Power)	9352173011	9352173011	9352173011	9352173011	
320	Wire Clamp Metal	313351219907	313351219907	313351219907	313351219907	
329	Coupling Pipe Assy	9355372015	9355372015	9353718013	9353718013	
381	Locking Spacer	313209391506	313209391506	313209391506	313209391506	
431	Bracket (Thermistor)	9356767001	9356767001	9356767001	9356767001	
447	Control Box Metal-A	9355634007	9355634007	9355634007	9355634007	
448	Control Box Metal-B	9355635004	9355635004	9355635004	9355635004	
457	Drain Pan Support-A	9356697001	9356697001	9356697001	9356697001	
458	Drain Pan Support-D	9356695007	9356695007	9356695007	9356695007	
462	Top Cover Plate	9355938020	9355938020	9355938013	9355938013	
464	Body-A	9355945035	9355945035	9355945011	9355945011	
465	Body-B	9355946032	9355946032	9355946018	9355946018	
467	Drain Port	313005415658	313005415658	313005415658	313005415658	
470	Separate Wall-B	9355691031	9355691031	9355691017	9355691017	
471	Pillar	9355982030	9355982030	9355982016	9355982016	
474	Turbo Fan Assy	9354332003	9354332003	9353129000	9353129000	
475	Turbo Fan Rubber	313005445054	313005445054	9352215001	9352215001	
476-1	Special Nut M8	313005360755	313005360755	313005360755	313005360755	
477	Bell Mouth	9355971003	9355971003	9355692007	9355692007	
478	Sensor M. Bracket	9352191008	9352191008	9352191008	9352191008	
479	Float Switch	313005416154	313005416154	313005416154	313005416154	
482	Pump Unit	9357855004	9357855004	9357855004	9357855004	
484	Hanger Metal	9355728003	9355728003	9355728003	9355728003	
488	Drain Pan Plug	313005174654	313005174654	313005174654	313005174654	
527	Protection Net	9356588002	9356588002	9356588002	9356588002	
628	Locking Spacer-B	313005446558	313005446558	313005446558	313005446558	
735	Distributor Assy	—	—	9353716019	9353716019	
795	Water Inlet Cover	9352218002	9352218002	9352218002	9352218002	
797	Separate Wall-C	9355690034	9355690034	9355690010	9355690010	
798	Pump Hook Bracket-A	9355629034	9355629034	9355629010	9355629010	
799	Pump Hook Bracket-B	9355630009	9355630009	9355630009	9355630009	
814	Body-C	9352192005	9352192005	9352192005	9352192005	
815-1	Terminal-3P	9356488005	9356488005	9356488005	9356488005	
834	Wire Cover	9355811002	9355811002	9355811002	9355811002	
835	Cushion-A (For Pump)	9352211003	9352211003	9352211003	9352211003	
836	Cushion-B (For Pump)	9356084016	9356084016	9356084016	9356084016	
860	Evaporator Support	—	—	9353153005	9353153005	
947	Body-Z	9359227007	9359227007	9359227007	9359227007	

RCW-18
RCW-25
RCW-36
RCW-45

When you order parts, please make a photocopy of this page and fill the number of the parts in the "Order" column.

GRILLE ASSY (CG-6C)

Ref. No.	Description	Part No.	Ord. Q'ty	Ref. No.	Description	Part No.	Ord. Q'ty
29	Supportor-B	9356723007		694	Cam	9356727005	
61	Decoration Plate	9357545004		695	Spacer	9357104003	
65	Jet Vane Motor	9358344002		696	Latch	9358709009	
93	Filter	9356719000		697	Reinforcement (Panel)	9356717006	
195	Clamp SKB-100	313361275805		698	Key Top	9355611008	
205	Wire Assy (Shield)	9357200019		700	Panel, Main	9356716016	
313	Hooking Wire	9357224008		705	Louver Assy	9356713015	
338	Motor Fixture	9356726008		710	Intake Grille	9357189017	
385	Indicator/Switch PCB Assy	9701546015		711	Filter Clamp	9356729009	
411	Supporter-A	9356722000		736	Operation Panel	9356480016	
690	Joint-A	9356731002		758	Decoration Plate-A	9356479010	
691	Joint-B Assy	9356732009		763	Receiver Cover	9356720013	
692	Shaft Holder	9356728019		854	Key Top-A	9357225005	
693	E-Washer	9357103006					









CONTROLLER PCB ASSEMBLY (Ref. No. 236)

Ref. No.	Description	Part No.	Ord. Q'ty	Ref. No.	Description	Part No.	Ord. Q'ty
IC1	IC μ PD78012HCW-022	9701380053		LF1	EMI Filter SU16VF-15030	0400134114	
IC2	IC MCT7805CT	0100649215		F1	Fuse 3.15A - 250V	0600222512	
IC5, 6	IC BA12003	0101650012		FH1, 2	Fuse Holder PFC5000-0502	0500158072	
IC7	IC HI0001	9701385010		VA1-2	Varistor TNR12G471K	0000038010	
Q1	Xstr 2SD1932	9701235018		SSR1	Relay G3M-202P-UTU	9701829019	
Q2, 5	Xstr DTC124ES	0000517010		K1, 2, 4, 5	Relay JQ1-12V	9701316014	
D1	Diode D2SB20	0000599023		CR1, 2	CR Absorbar RPEL-121204	9701125012	
D2	Diode MTZJ15A	0000852081		RC1	CR Module ARCL8FS103J102J103M	0200301037	
D3-5	Diode 1SR139-200	0000353113		RC2	CR Module ARCL14FS103J102J103M	0200301020	
R1, 2	Res. Carbon 1/4W 5.6k Ω \pm 5%	0201038918		RC3, 4	CR Module ARCL12FS103J102J103M	0200301013	
R3, 4, 7-15, 17, 19-21	Res. Carbon 1/4W 10k Ω \pm 5%	0201005019		SA1	Arrestor DSA-362MA-05	0600168032	
R18	Res. Carbon 1/4W 390 Ω \pm 5%	0201038673		SW2	Switch, Slide DSS803	9701392018	
R22	Res. Metal 47 Ω \pm 5%	0201038468		HT1	Heat Sink PUG26-25	9701428014	
R23	Res. Metal 1k Ω \pm 5%	0201035758		CN1	Plug, PCB 53406-9910	0500951048	
R24	Res. Carbon 1.2k Ω \pm 5%	0201038772		CN2	Plug, PCB B2P3-VH-B	0500011728	
R5	Res. Metal 3.32k Ω	0201028568		CN3	Plug, PCB B2P3-VH-B-C	0500011773	
R6	Res. Metal 10.5k Ω	0201028537		CN4	Plug, PCB 53331-0210	0501033019	
C1, 4	Cap. Plastic 250V 0.1 μ F	0300894835		CN5	Plug, PCB 5430C063	0500957026	
C2, 3	Cap. Ceramic 4700pF	0300727546		CN6	Plug, PCB B2P3-VH-B-R	0500011766	
C5	Cap. Elec. 50V 2200 μ F	0301206026		CN7	Plug, PCB B2B-XH-AM	0500005321	
C6	Cap. Elec. 50V 10 μ F	0300122525		CN8	Plug, PCB 53405-0210	0500940011	
C7, 16, 17, 28	Cap. Elec. 25V 10 μ F	0300122273		CN9	Plug, PCB B2P-VH-B	0500011124	
C8	Cap. Elec. 25V 1100 μ F	0301016021		CN10	Plug, PCB B2P-VH-B-C	0500011568	
C9, 12, 13, 27, 30	Cap. Ceramic 0.1 μ F	0300988251		CN15	Plug, PCB B3B-XH-AM	0500005338	
C10	Cap. Elec. 25V 100 μ F	0301016014		CN16	Plug, PCB B2B-XASK-1-A	0501045012	
C11, 26, 29	Cap. Ceramic 50V 0.01 μ F	0300013113		CN17	Plug, PCB B12B-XASK-1-A	0501045111	
C20-24	Cap. Ceramic 50V 1000pF	0300011096		CN18	Plug, PCB B4B-XH-AM	0500005314	
X1	Ceramic Resonator EF0EC8384T4	9701261017		CN19	Plug, PCB B3P-SHF-1AA	0500006021	
				E	Wire w/Terminal GRN L=210	9701325016	









INDICATOR PCB ASSEMBLY / SWITCH PCB ASSEMBLY (Ref. No. 385)

Ref. No.	Description	Part No.	Ord. Q'ty	Ref. No.	Description	Part No.	Ord. Q'ty
D201	Diode SLR325VC	0000813259		PHA201	Remote Control Amplifier	0100417050	
D202	Diode SLR325MC	0000813242		SW301	Switch, Slide 8ss1012-1	9701426010	
D203	Diode SLR325DC	0000813235		SW302	Switch, Slide JSA1220-0301	9701310012	
R201	Res. Carbon 1/4W 1k Ω \pm 5%	0201038758		SW303	Switch, Push EVQ-PAG-04	9700450016	
R202	Res. Carbon 1/4W 820 Ω \pm 5%	0201038734		CN201, 301	Wire w/Connector L=1000	9701545018	
R203	Res. Carbon 1/4W 1.2k Ω \pm 5%	0201038772		CN202, 302	Wire w/Connector L= 40	9701547012	
C201	Cap. Elec. 25V 10 μ F	0300004258		B2201	Buzzer PKM13EPY-4000-TF01	9701298013	
C202	Cap. Ceramic 0.1 μ F	0300988251					

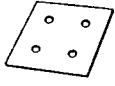

OUTDOOR UNIT ACCESSORIES

Name and Shape	Part No.			
	ROCW-18	ROCW-25	ROCW-367	ROCW-457
Power cap 	—	—	9352173011	9352173011
Auxiliary pipe assembly 	—	—	9355292016	9355292016
Edge cover 	—	—	9352436000	9352436000
Tapping screws 	—	—	301463040100	301463040100
Binder 	—	—	313035356905	313035356905
Putty 	—	—	303020200114	303020200114
Coupler heat insulation 	—	—	313005074759	313005074759
Hexagon wrench 	9351228019	9351228019	—	—

INDOOR UNIT ACCESSORIES

Name and Shape	Part No.
Coupler heat insulation 	9350716029 } 1 each 9352766015 }
Special nut A (large flange) 	313005446653
Special nut B (small flange) 	313005446759
Template 	9357168005
Remote controller 	9358650042
Battery (penlight) 	313187358304
Remote controller holder 	9358795002
Tapping screw (medium) ($\phi 4 \times 14$) 	301141164144
Machine screw (small) ($\phi 3 \times 4$) 	0700139024

GRILLE ACCESSORIES

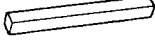
Bolt 	9356189001
Washer 	301801155020
Spring washer 	301821150218
Blower cover insulation 	9357227009



MANUFACTURER:

Fuji Denki Sosetsu Co., Ltd.

Tokyo, Japan

9806K1349

July 1998 Printed in Japan



Большая библиотека технической документации
<https://splitsystema48.ru/instrukcii-po-ekspluatacii-kondicionerov.html>
каталоги, инструкции, сервисные мануалы, схемы.